



Kevin Widmer

Director of Strategic Marketing
Spansion Inc.

Flash Memory Summit

SPI Flash Memory: Future Trends and Applications

August 2009



FLASH FORWARD



SPI Adoption Trend

NOR TAM

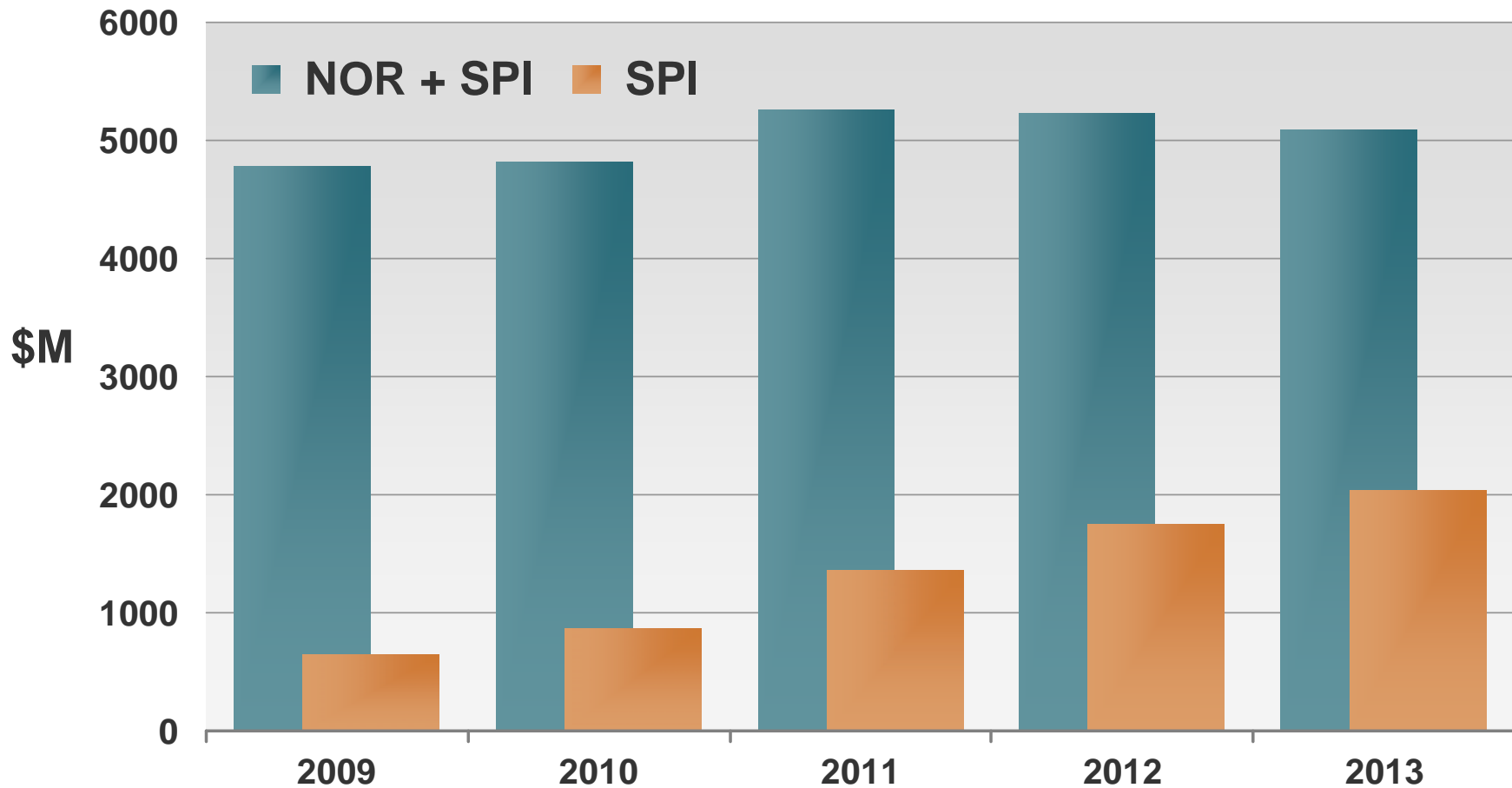

SPI at 40% of NOR TAM by 2013
33% CAGR growth driven by Mid-High density Multi I/O

Source: WebFeet August, 2009

Market Drivers

Advantage of SPI NOR Interface

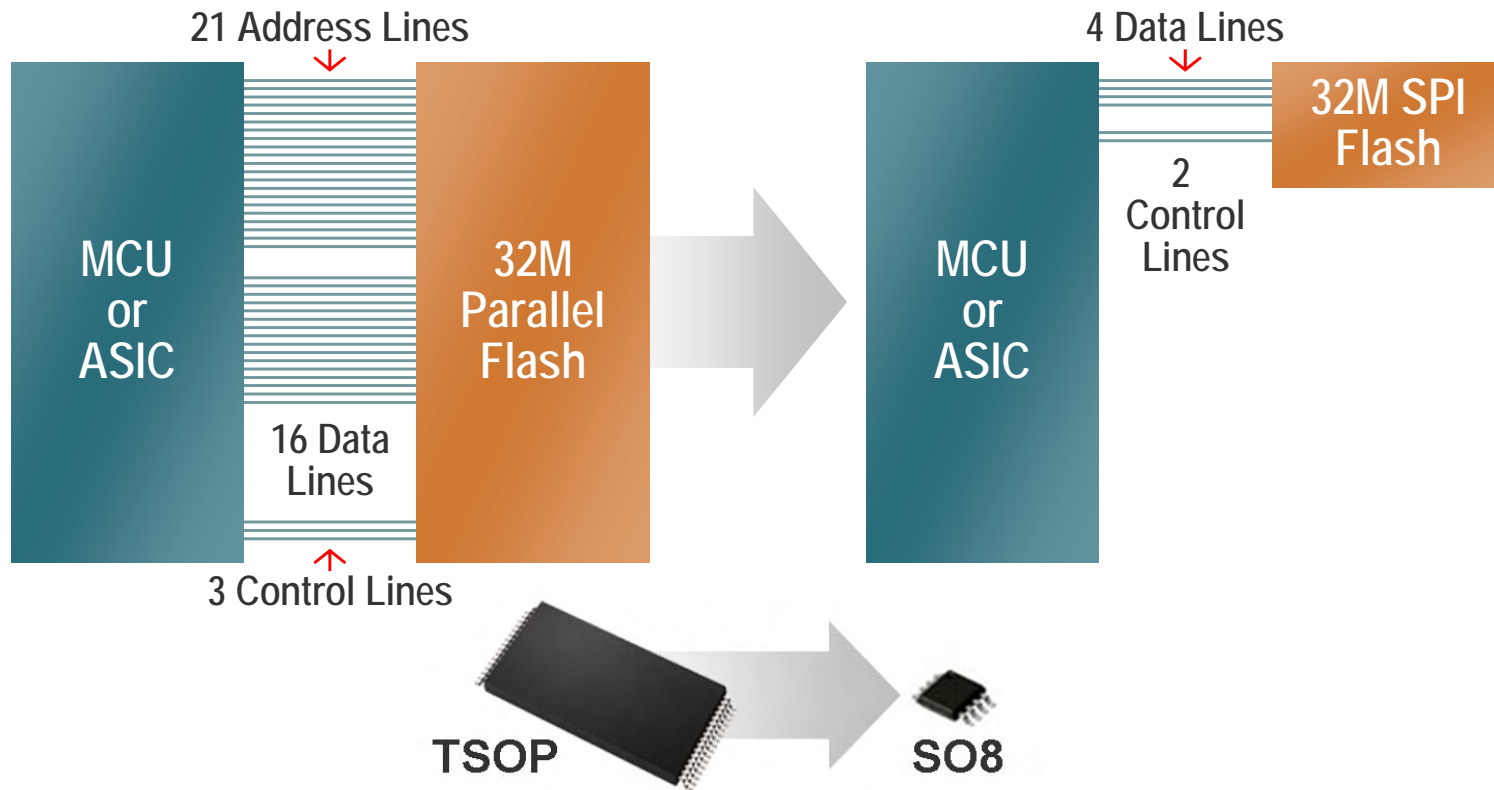

Package Type	SO8	TSOP48
Package Dimensions	30mm ² (5x6)	240mm ² (12x20)
Number of pads	8	48

Over 80% reduction in package size and pin count

Memory Subsystems

SPI NOR Adoption in High Growth Markets

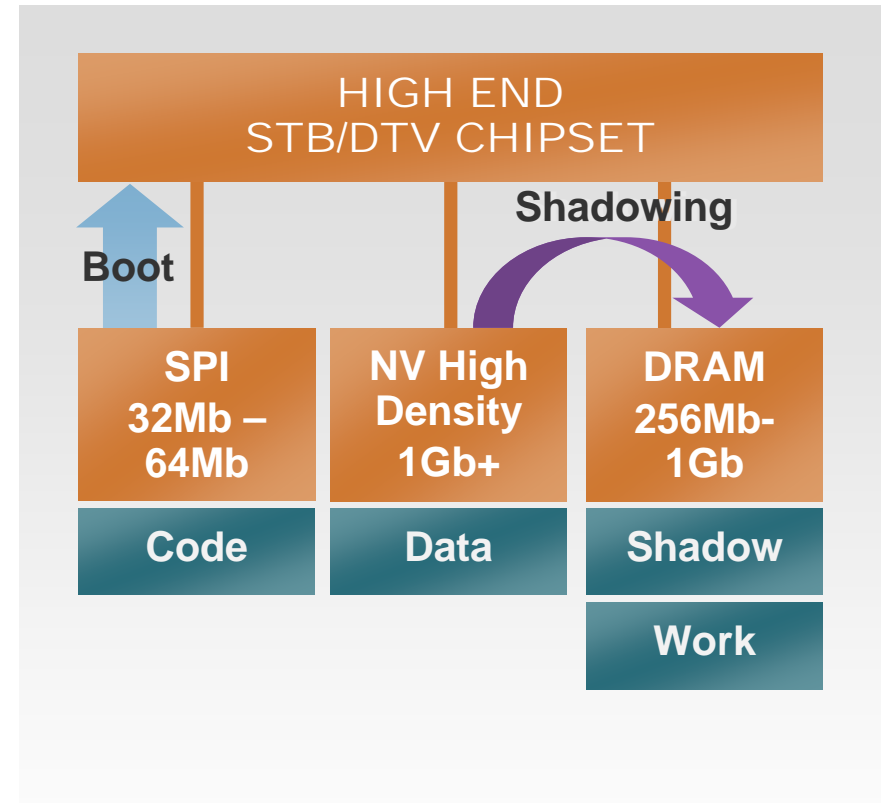
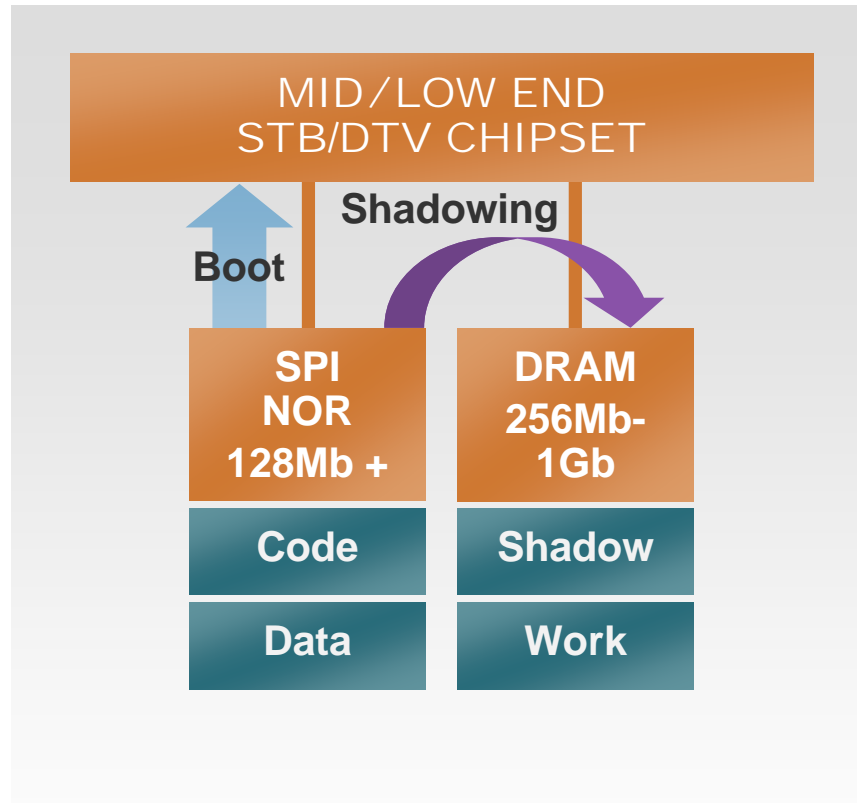

SPI Multi-IO gaining momentum in new usage models

Memory Performance Evolution

Memories Bandwidth Over Time

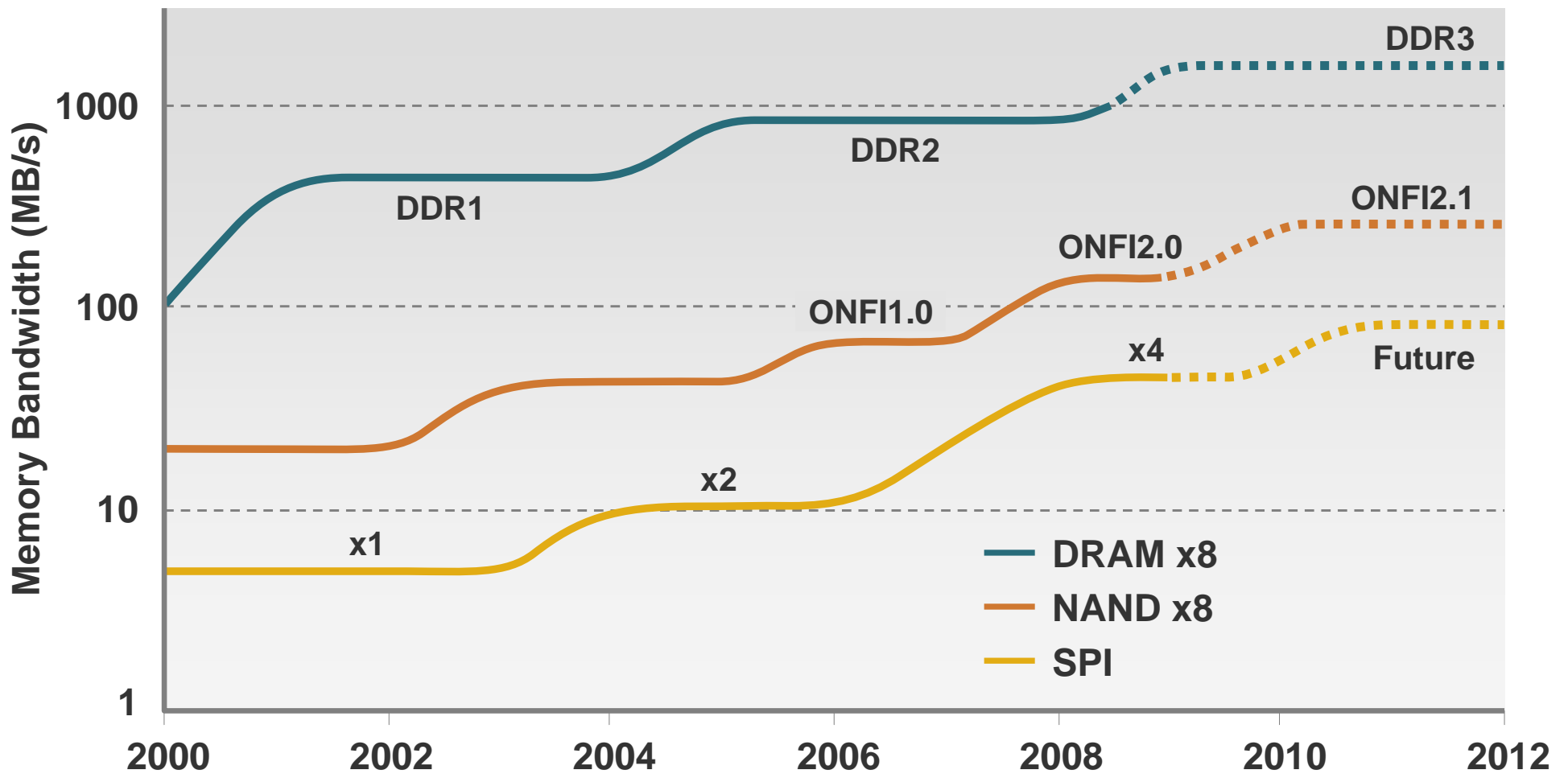

Performance Comparison 3V NOR Flash Memory Solutions

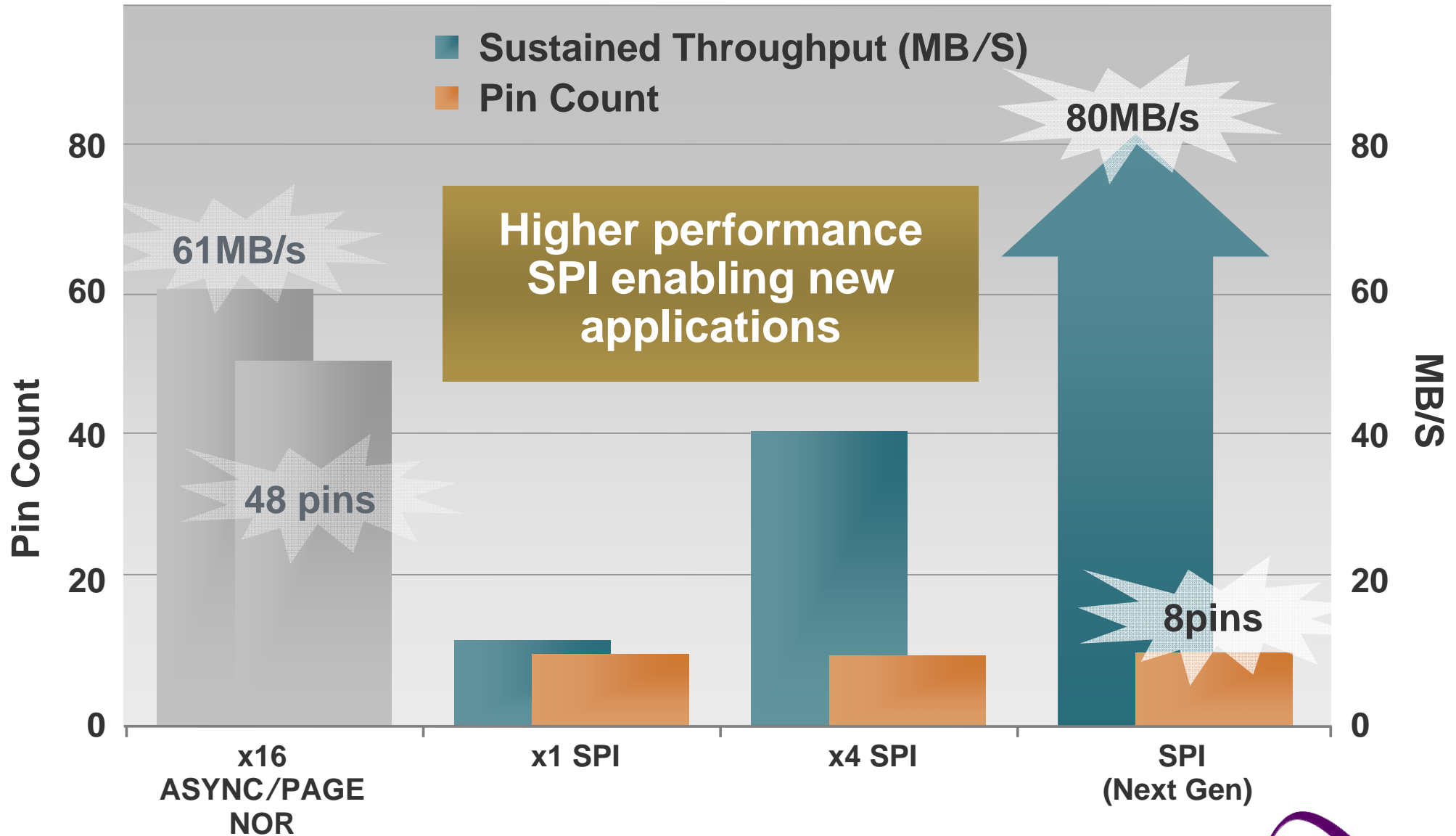

Application Performance Requirements





Trademark Attribution



Spansion[®], the Spansion logo, MirrorBit[®], MirrorBit[®] Eclipse[™], ORNAND[™], EcoRAM[™] and combinations thereof, are trademarks of Spansion LLC in the U.S. and other countries. Other names used are for informational purposes only and may be trademarks of their respective owners.

This document is for informational purposes only and subject to change without notice. Spansion does not represent that it is complete, accurate or up-to-date; it is provided “AS IS.” To the maximum extent permitted by law, Spansion disclaims any liability for loss or damages arising from use of or reliance on this document.