



# High Capacity SSDs in the Enterprise

**Scott Shadley**

Sr. Technical Manager

SSD Marketing

STEC, Inc.





# Consideration Required...

## Interface Technology

Much like the movie format wars... BetaMAX? HD DVD?

## Cost Requirements

Designer desires vs Price club budget

## Media Restrictions

Microfiber or Leather?

## The Solution

What's under the hood

# Interface Technologies

## Synchronous vs. A-Synchronous NAND

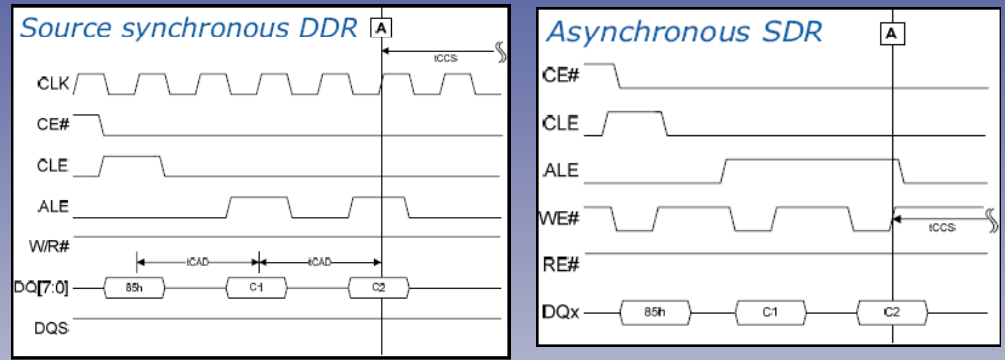

Fibre Channel, SAS, SATA protocols

3.5"/2.5"/1.8" Form Factors

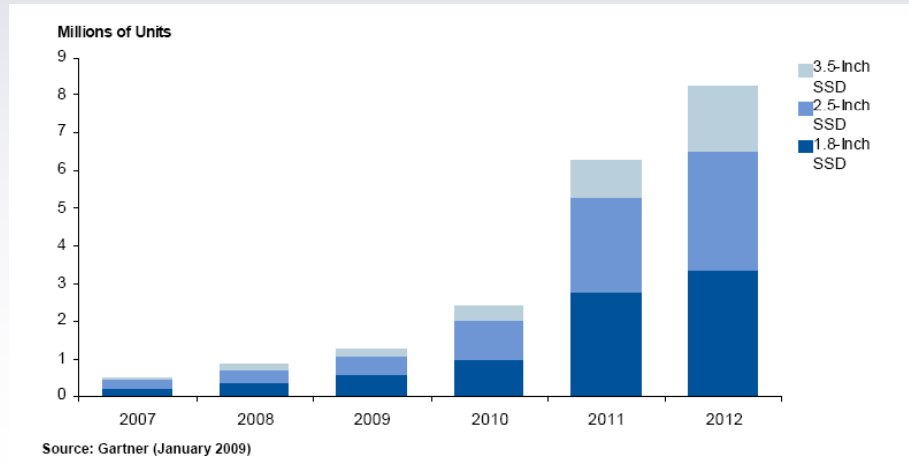

# MLC NAND Considerations

The path to the best TCO of the SSD usage model

SLC vs. MLC media  
the pricing war

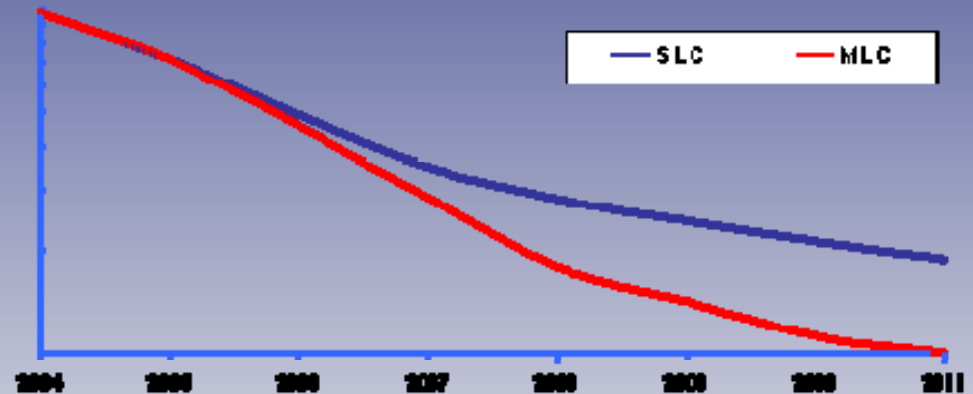

The Challenges with enabling MLC

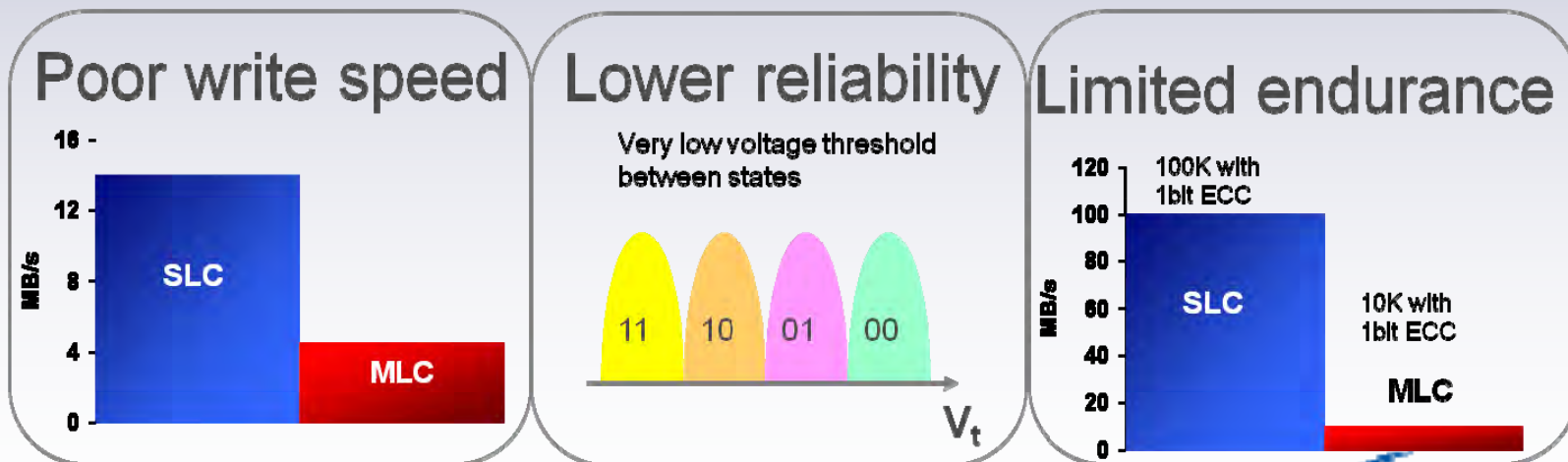

# What needs to be done for MLC to work

## Controller technology

- Advancements in ECC
- Write Mitigation techniques
- Read/Program Disturb prevention

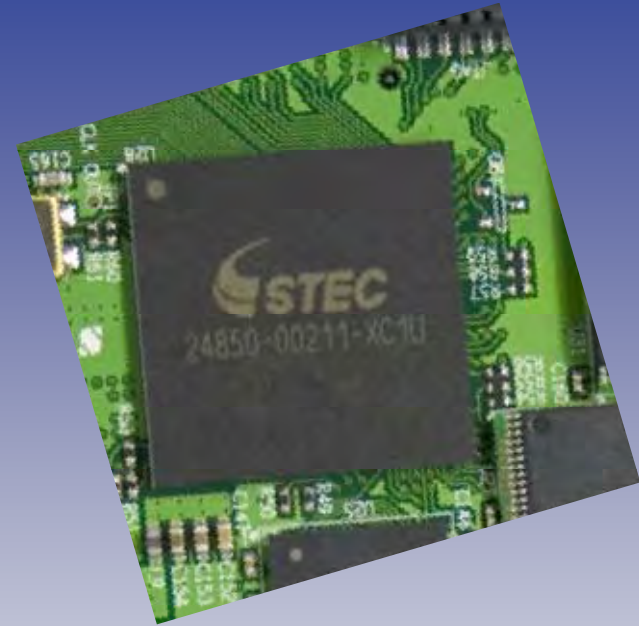

## Data Endurance Management

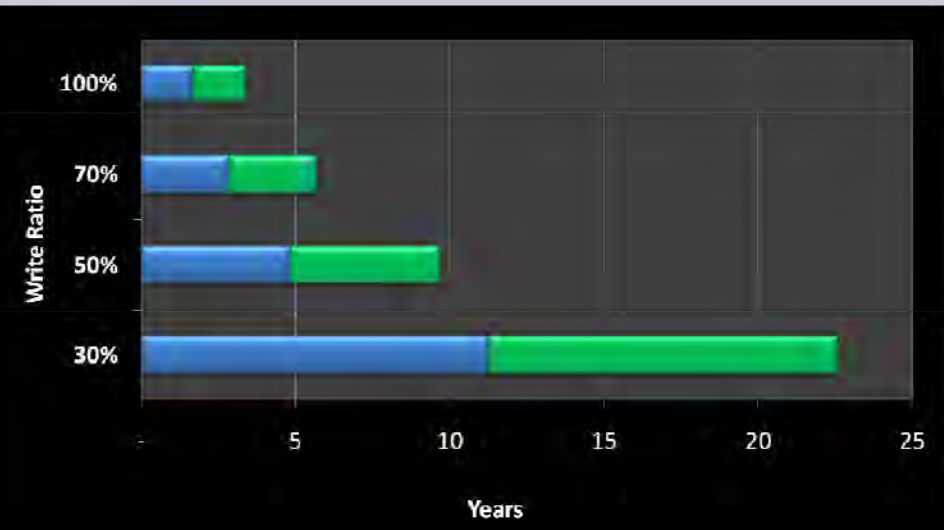

**SLC  
vs.  
MLC**

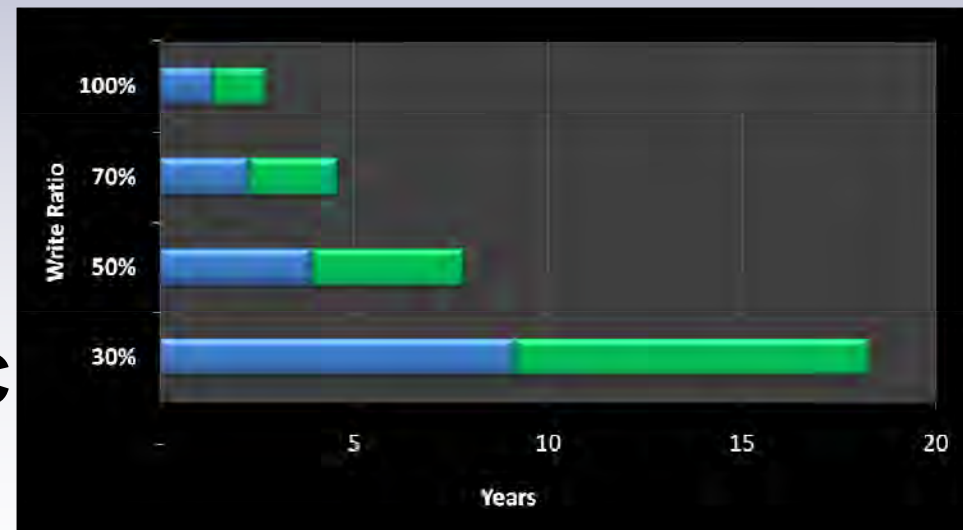

# Ensuring Customer Data is Safe

Just a “snapshot” of the available S.M.A.R.T attributes for use  
None are as complete as the STEC attribute set to date.

Attribute	Flags	Type
Program Fail Count	0x32	Advisory
Reallocated Sector Count	0x32	Advisory
Erase/Program Cycle Count	0x32	Advisory
Wear Leveling Count	0x32	Advisory

## Comprehensive Endurance monitoring

STEC monitors and tracks in all drives

Erase activity counter

Error conditions and events

# Reaching High Capacity SSDs

Utilizing the proper techniques and solutions will enable MLC SSDs moving forward

MLC-Based SSDs are being qualified at key customers

Endurance mitigation is a key in providing a long life to SSDs

Controller technology must remain steps ahead of the media