



DESIGN CHALLENGES FOR HIGH SPEED HIGH DENSITY LOW PROFILE BOARD TO BOARD INTERCONNECTS

SAUJIT BANDHU
ROY LIM
YUN LONG QIAO
ALEXANDER W. BARR





Agenda

- Trend in Enterprise Equipment Market
- Trend in Enterprise Hard Disk Drive (SSD)
- Need for High Capacity/ Small Form Factor Storage Devices
- Need for high speed low profile B2B interconnects
- Constraints for high speed low profile high density B2B interconnects for SSD
- Address for resolution to overcome design constraints for high speed low profile high density B2B Interconnect
- Address for resolution to overcome design constraints for high speed Ultra low profile high density B2B Interconnect
- Q & A





Enterprise Storage Market Trend

WORLDWIDE STORAGE SYSTEMS HARDWARE, SOFTWARE, AND SERVICES CUSTOMER REVENUES

(In billions of dollars)

	2009	2010	2011	2012	2013	2014	CAGR (%) 2009-14
Enterprise storage systems	26.2	28.1	29.3	30.5	31.7	32.7	4.6
Storage network (FC switch and HBA, and FCoE CNA)	3.8	4.2	4.4	4.6	4.5	4.1	1.3
Storage services	31.4	32.2	33.7	35.4	37.4	39.6	4.7
Storage software	11.5	12.0	12.7	13.5	14.5	15.6	6.3
Total	72.9	76.5	80.1	84.0	88.1	92.0	4.8

CAGR-Compound annual growth rate. FC-Fibre Channel. HBA-Host bus adapter.

FCoE-Fibre Channel over Ethernet. CNA-Converged Network Adapter.

Source: IDC's December 2010 forecast report.

WORLDWIDE EXTERNAL ENTERPRISE STORAGE SYSTEMS REVENUE FORECAST

(In billions of dollars)

INSTALLATION ENVIRONMENT	2009	2010	2011	2012	2013	2014	CAGR (%) 2009-14
Direct-attached storage (DAS)	3.6	3.2	2.8	2.6	2.5	2.4	(7.7)
Mainframe networked (ESCON/FICON SAN)	0.7	0.6	0.5	0.5	0.5	0.5	(7.5)
Open networked	15.0	17.0	18.6	20.0	21.4	22.6	8.5
Network-attached storage (NAS)	3.8	4.5	4.7	5.0	5.3	5.5	7.6
Storage area network (SAN)	11.2	12.6	13.8	15.0	16.1	17.1	8.7
Fibre channel	9.1	9.8	10.3	10.5	10.5	10.4	2.5
iSCSI	1.9	2.5	3.0	3.6	4.1	4.8	19.8
Fibre channel over Ethernet	...	0.0	0.3	0.6	1.0	1.4	...
Switched SAS (SAS SAN)	0.1	0.2	0.2	0.3	0.3	0.4	24.9
InfiniBand	0.1	0.1	0.1	0.1	0.2	0.2	27.4
Total	19.3	20.8	22.0	23.1	24.4	25.4	5.7

iSCSI-Internet small computer systems interface. ESCON-Enterprise system connection.

FICON-Fiber connection.

Source: IDC's August 2010 forecast report.





Server Virtualization Market Trend

WW Server Virtualization Shipment Forecast, 2005-2013

Source: IDC



Source: IDC





Growth in Solid State Drive Market

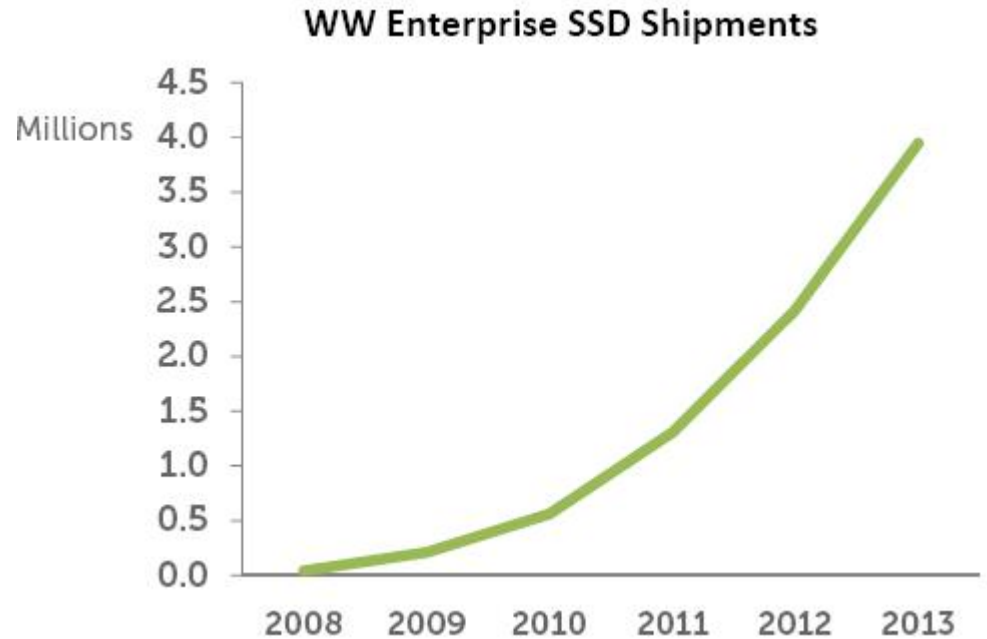
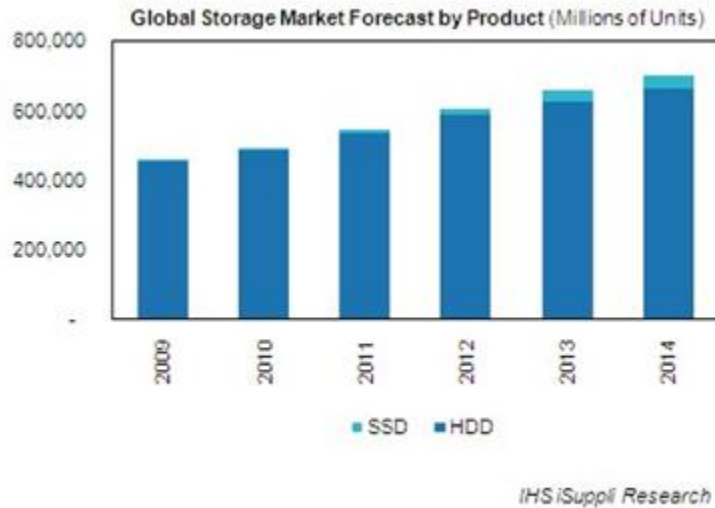

Source: IDC 2009 WW Solid State Drive 2009-2013 Forecast Update

<http://www.isuppli.com/Memory-and-Storage/MarketWatch/Pages/Storage-Industry-to-Maintain-Growth-in-2011-with-Strong-Enterprise-Demand.aspx>



SFF Standard for SSD Thickness

SFF-8201 Rev 2.4

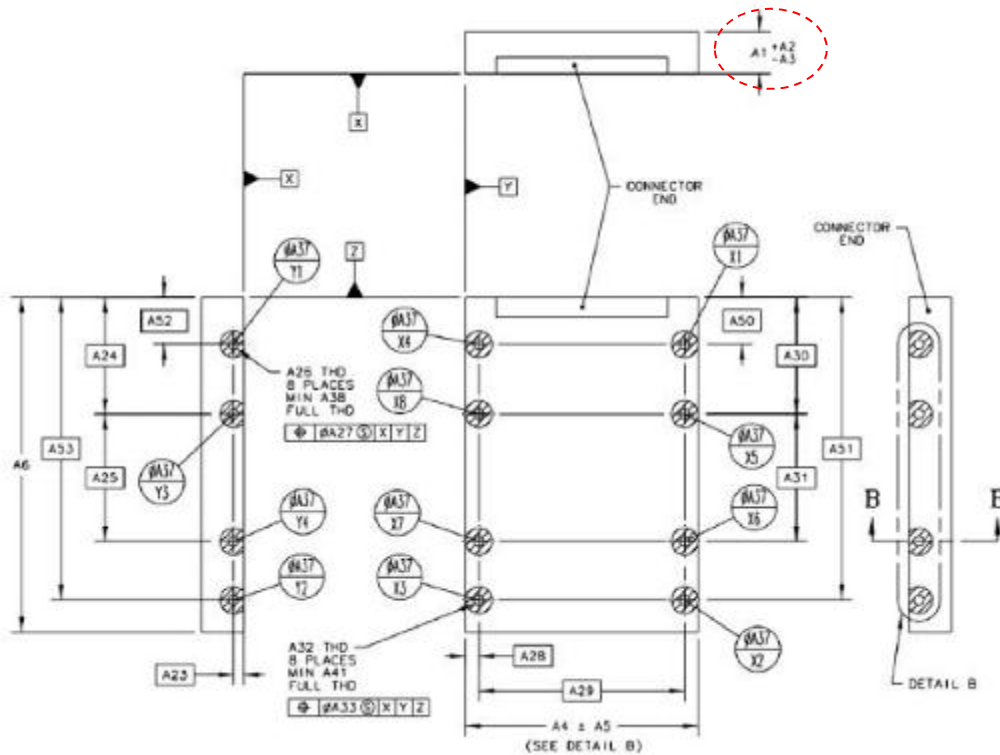

Dimension	Millimeters	Inches	Comments
A 1	19.05	0.750	
A 1	17.00	0.669	
A 1	15.00	0.591	
A 1	12.70	0.500	
A 1	10.50	0.413	
A 1	9.50	0.374	A2=A3=0.20 mm (0.008")
A 1	8.47	0.333	
A 1	7.00	0.276	



Source: iTech News Net



Source: iTech News Net



2.5" Double Layer PCB SSD

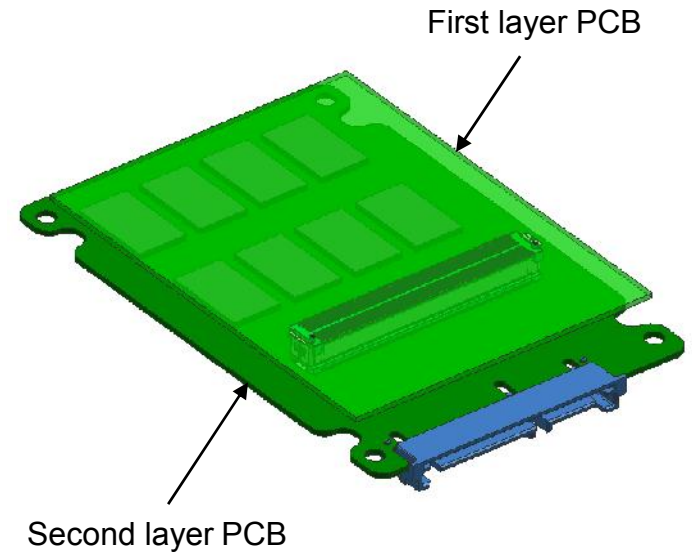
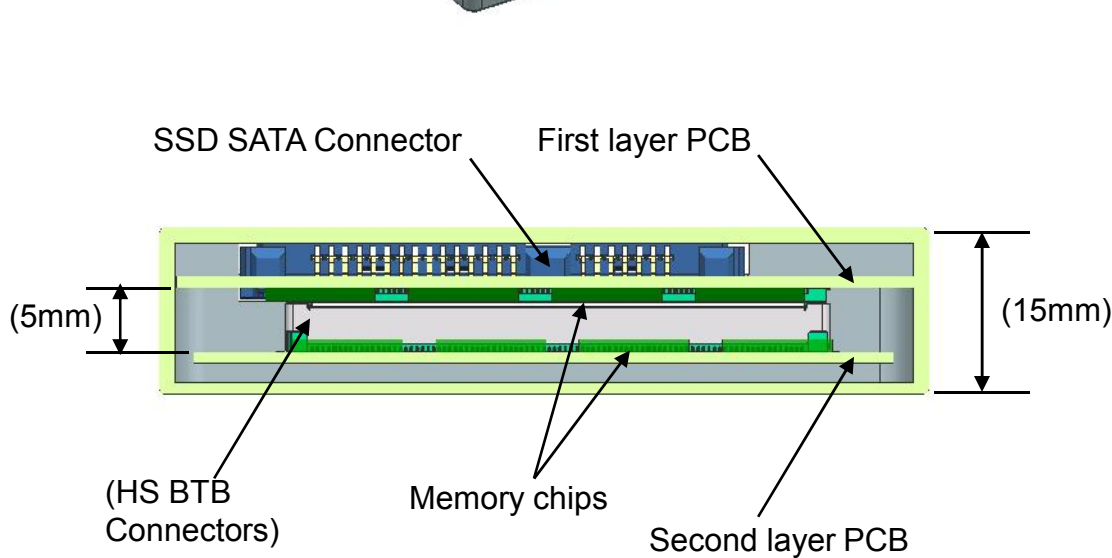
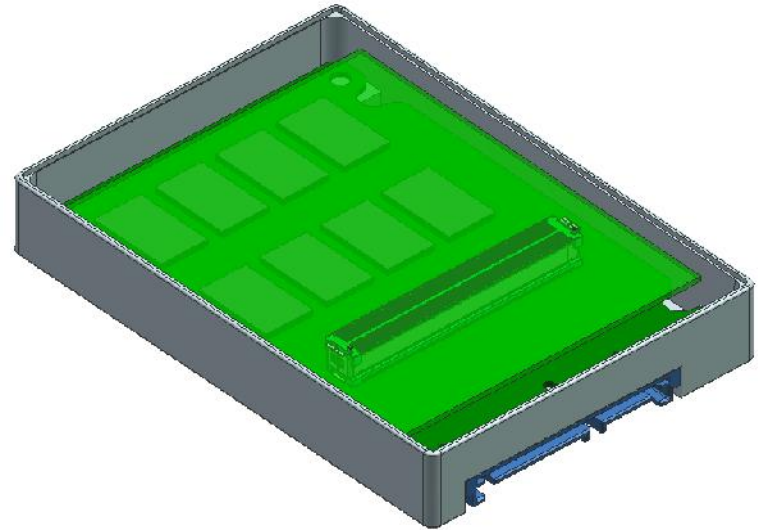
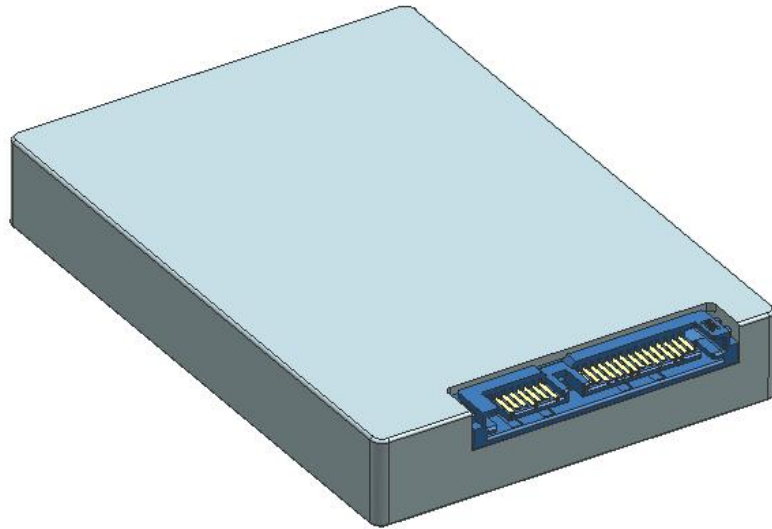



Overall Size of 3M 180P HS-BTB Connectors

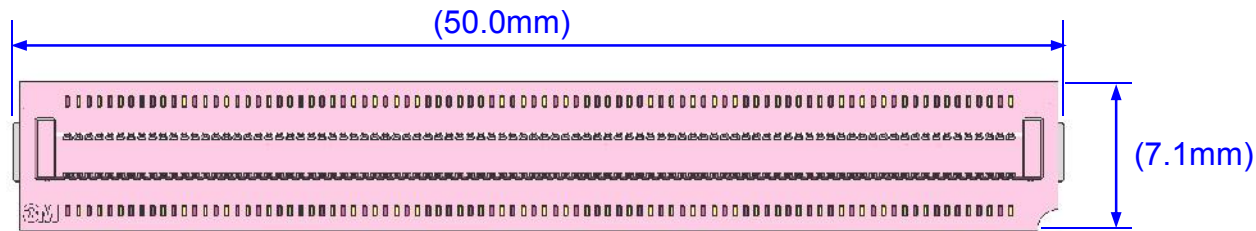

Plug Connector

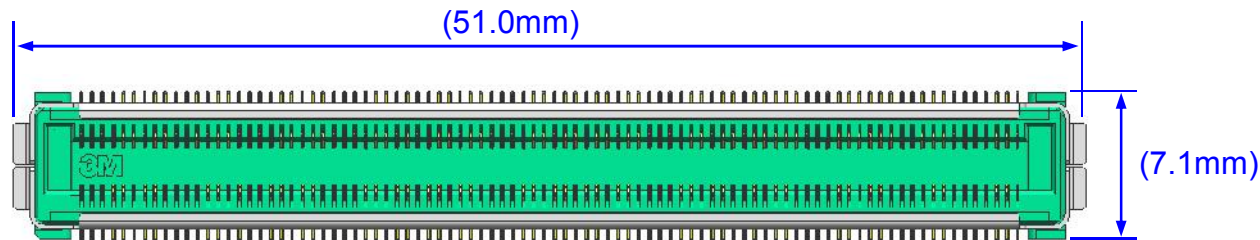

Socket Connector

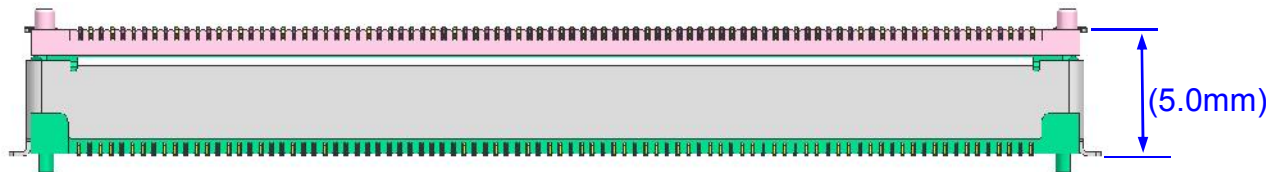

Mated Connectors



Partial Shielding Features on Individual Connectors

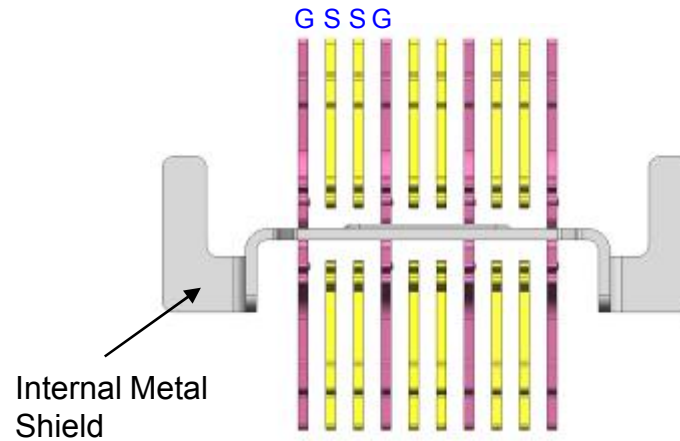
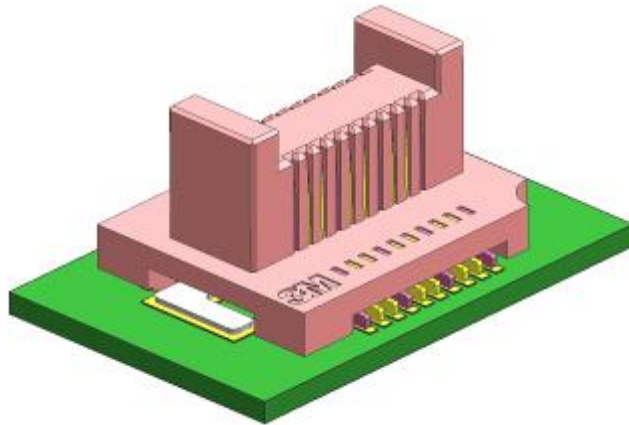

Possible to configure for Single Ended or Differential Signal

Plug

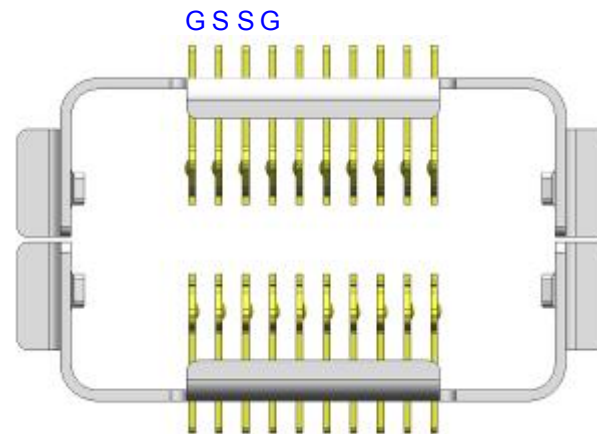
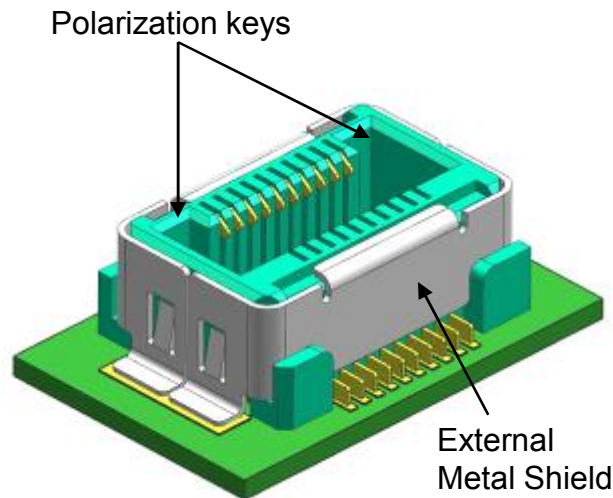

Possible to configure for Single Ended or Differential Signal

Socket

Partially Shielded Connectors Lower Cost



Full Box Shielding Upon Mated Connectors

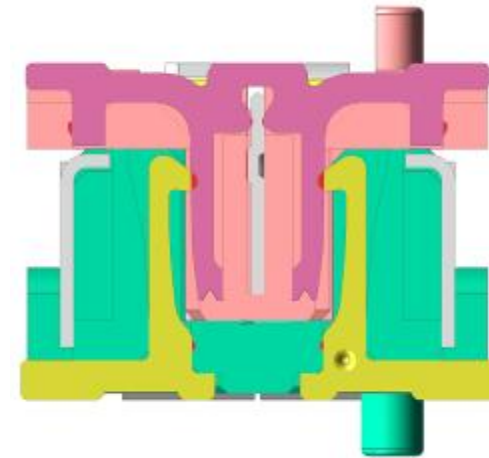
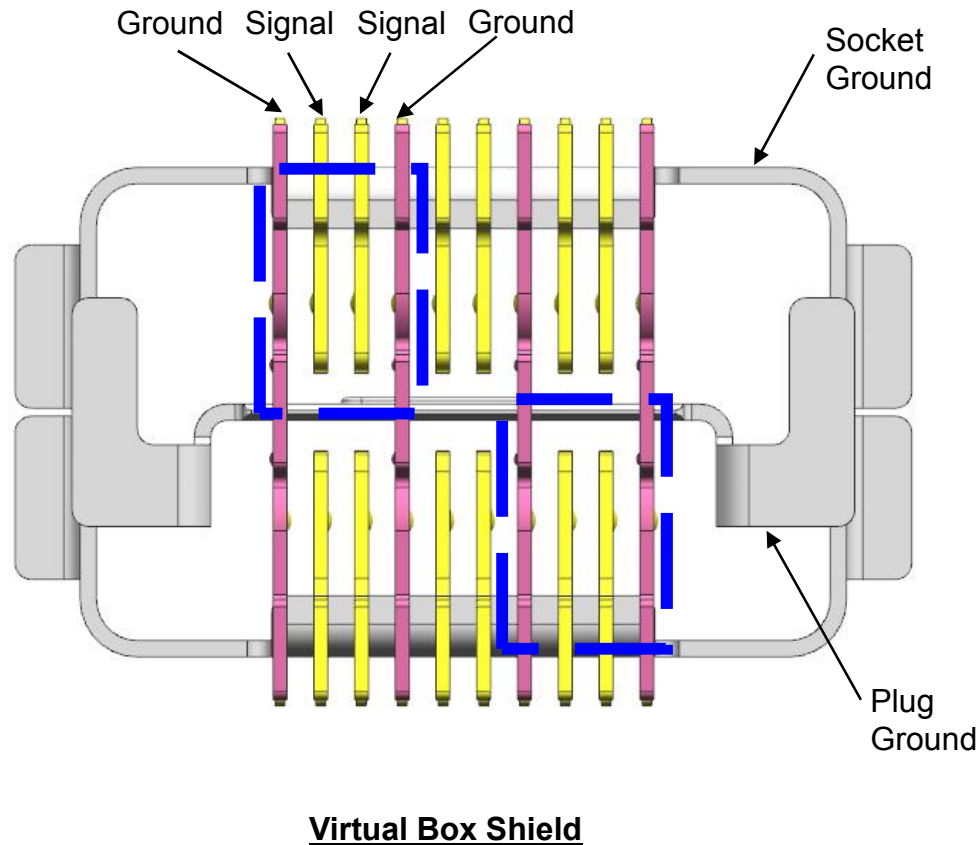

Cross-sectional View with Ground Contact

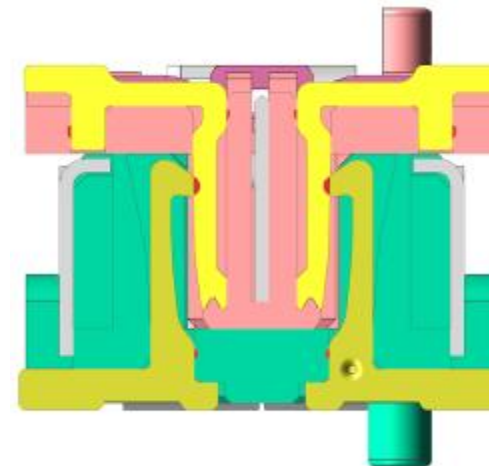

Cross-sectional View with Signal Contact

Co-Axial Box Structure Leads to Superior Signal Integrity Performance



Alternative Application for HS-BTB

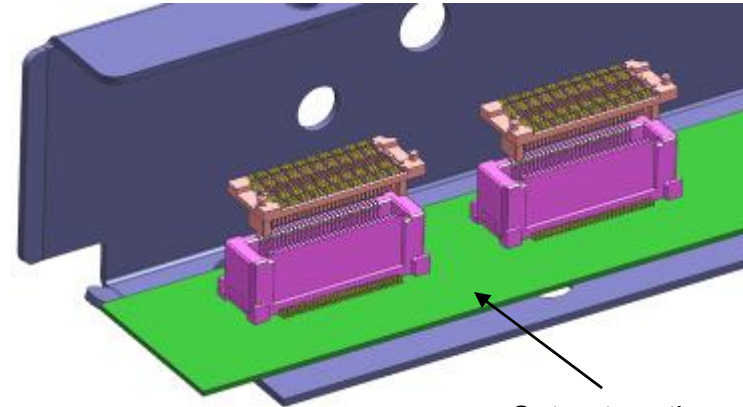
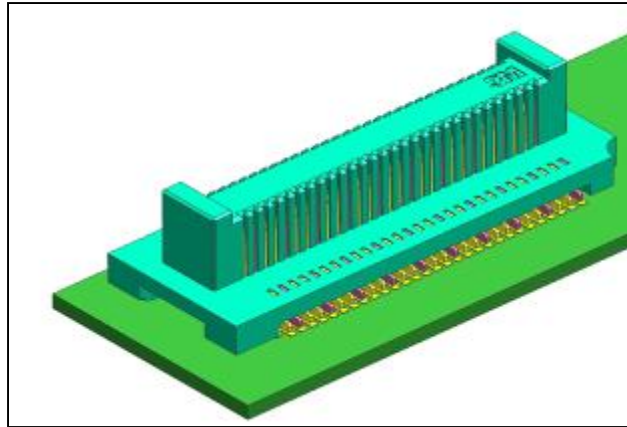

Cut out portion of main board

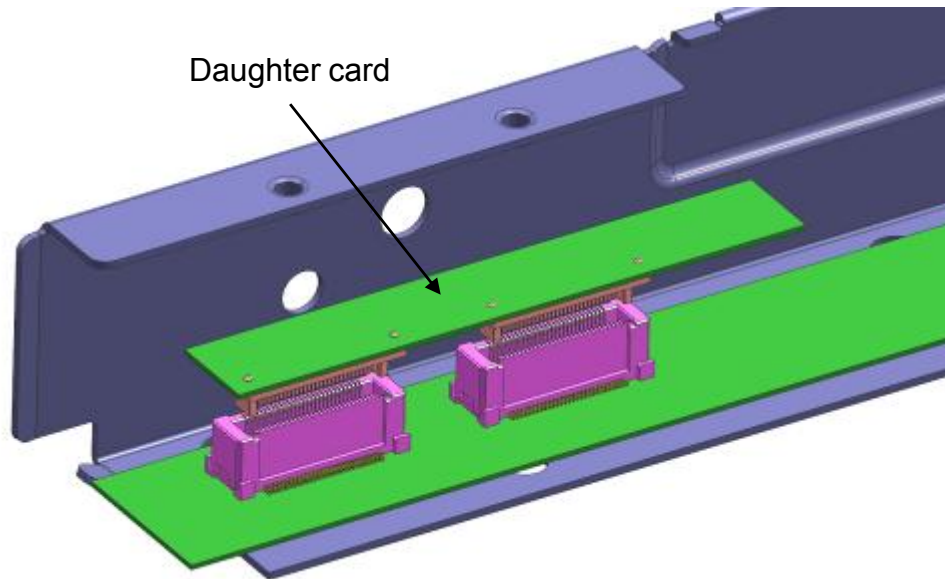

Daughter card

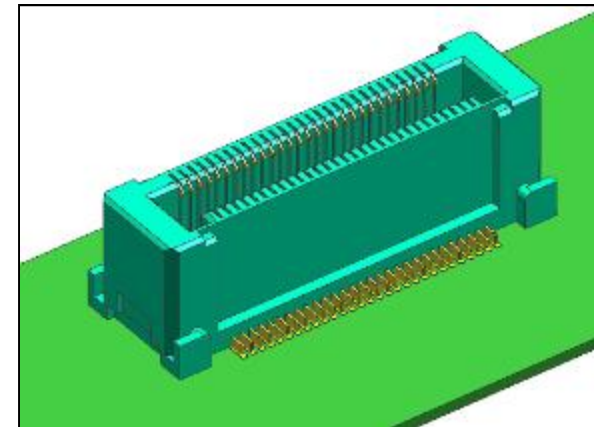

Mechanical Simulation for HS BTB Connector

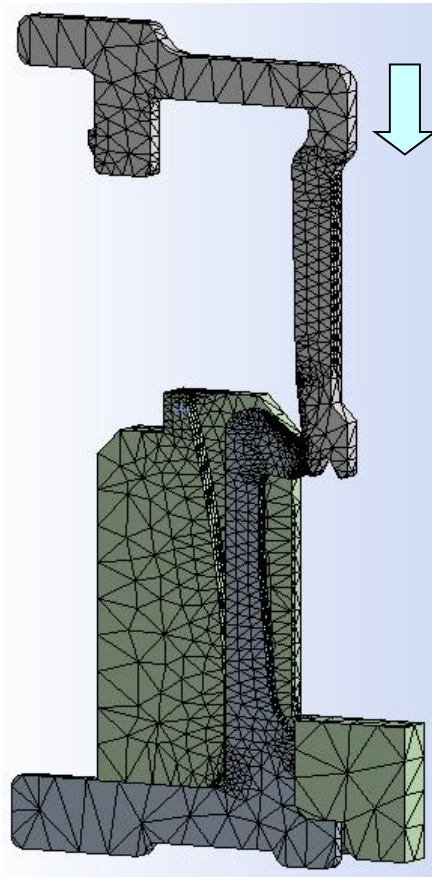

FEA Setup

Added extra chamfer to reduce insertion force

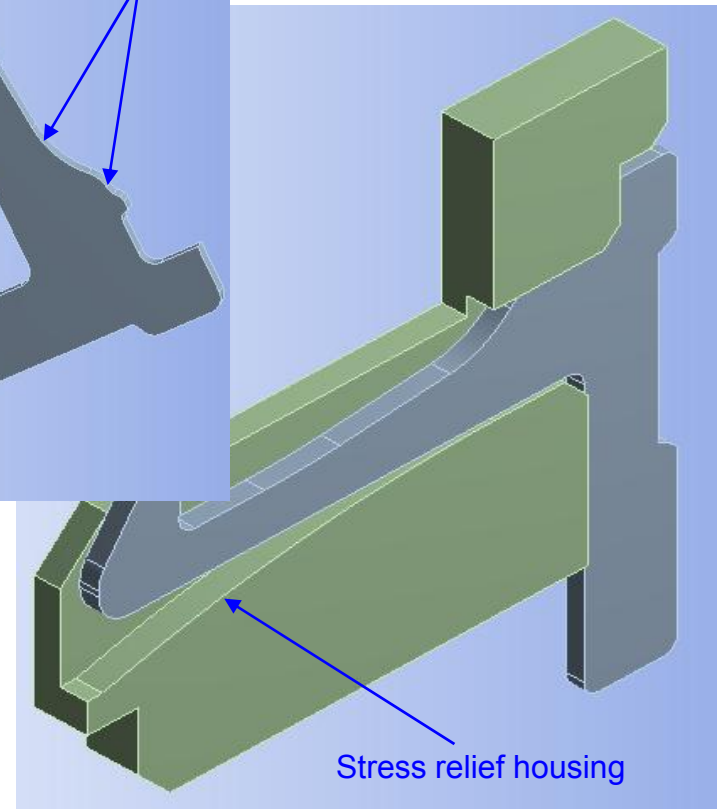
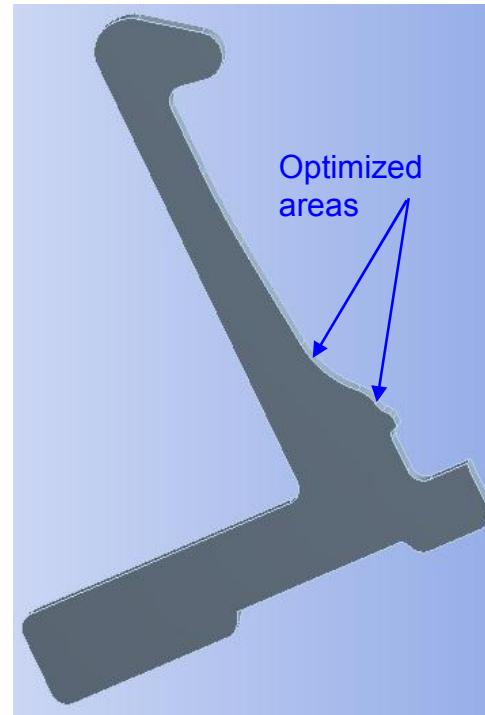
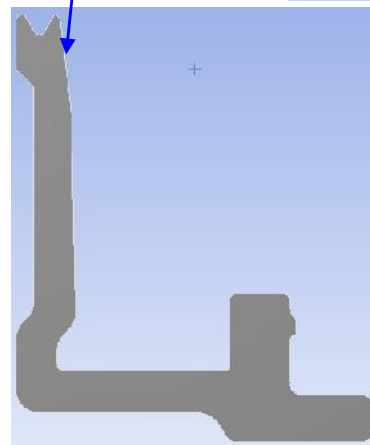



Mechanical Performance – Optimization

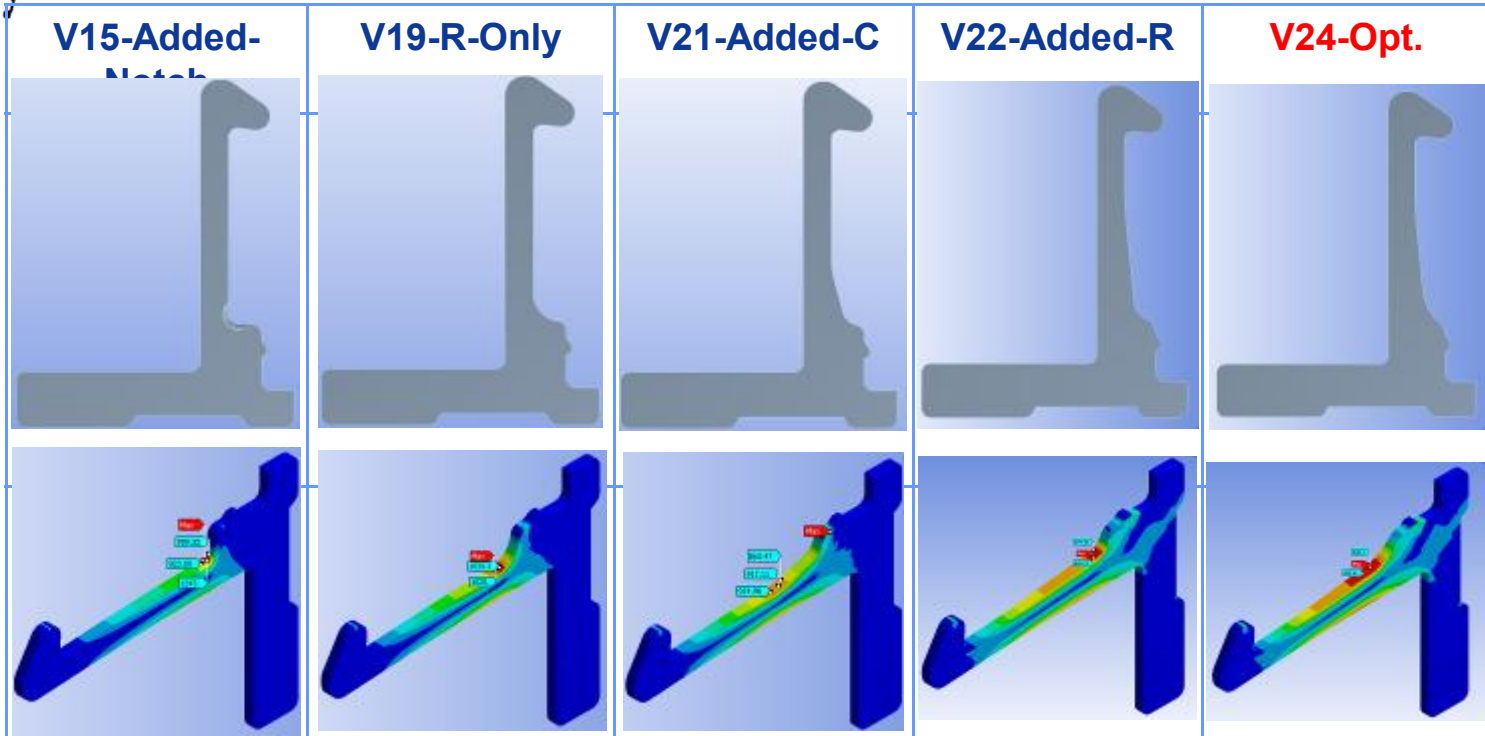



	V15-Added-Notch	V19-R-Only	V21-Added-C	V22-Added-R	V24-Opt.
Max. Stress (Mpa)	1376	1068	1064	894	859
Max. Strain	1.38%	0.97%	0.94%	0.81%	0.78%
Max. Insertion Force (N)	0.18	0.21	0.27	0.31	0.33
Normal Force (N)	0.75	0.86	1.09	1.30	1.35

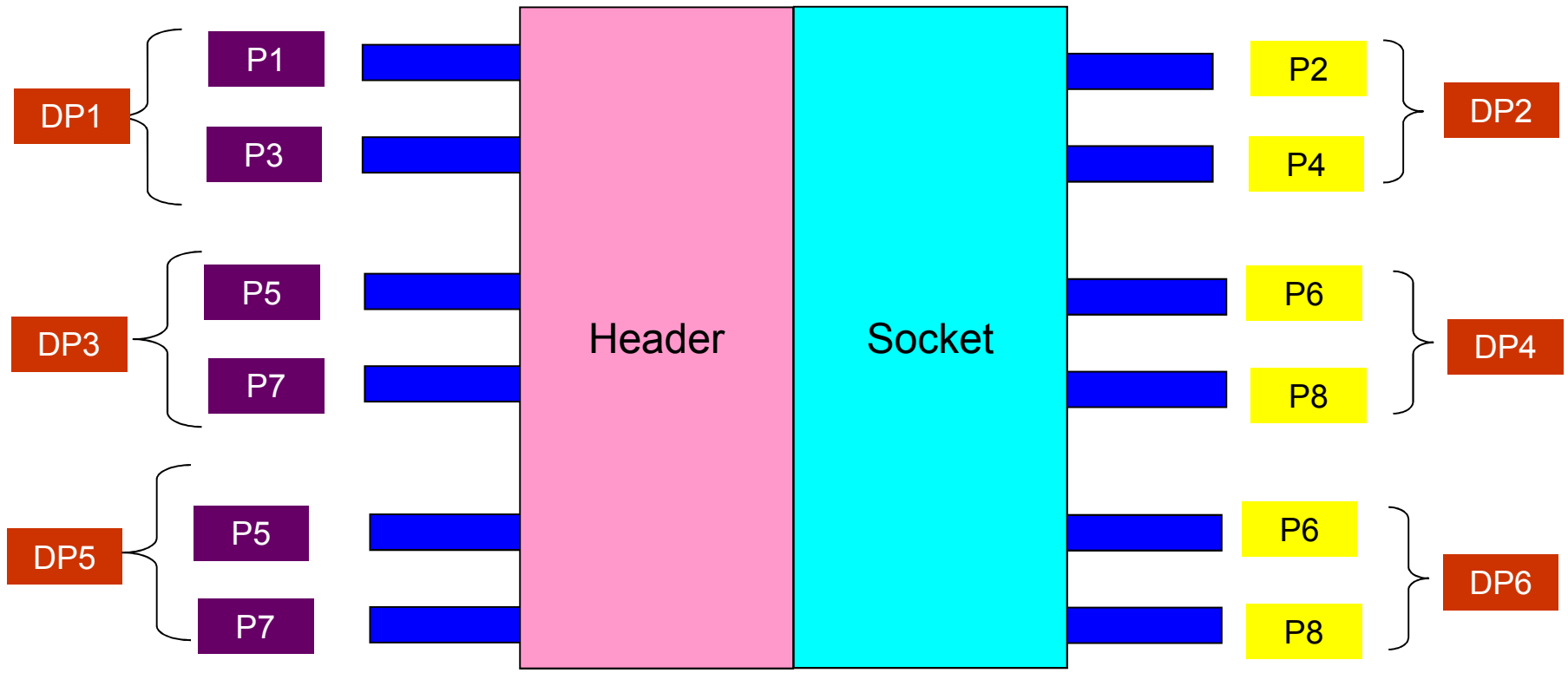

Schematic of Ports Assignment



 → Input Ports
 → Output Ports

 DP Differential Ports



Modeling Information

- Dielectric Material: LCP with Dielectric Constant 3.5 and Loss Tangent 0.01
- Contact Material: Phosphor Bronze with Conductivity $8.7e+06$ S/M
- 12 Port Simulation
- With Ground Shield



HS-BTB Measured Vs Simulation Comparison

Fixture De-embed out

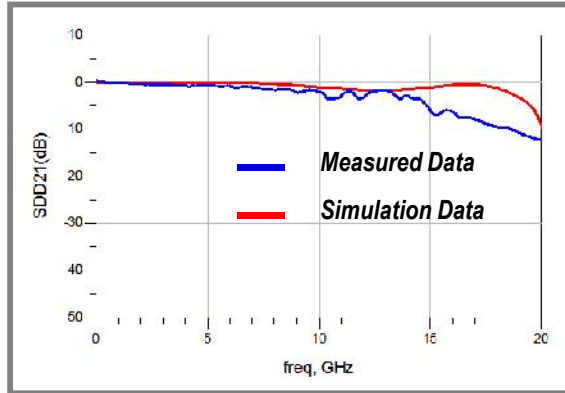

Fixture De-embed out

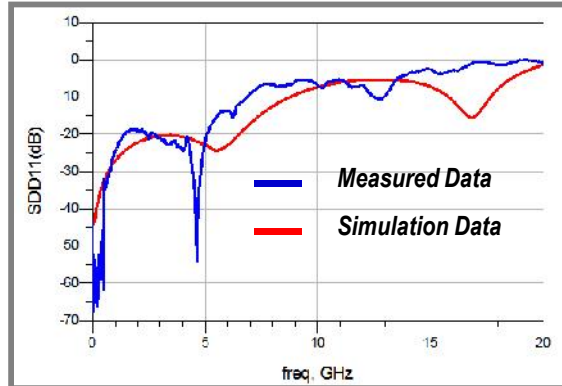

Test Set Up

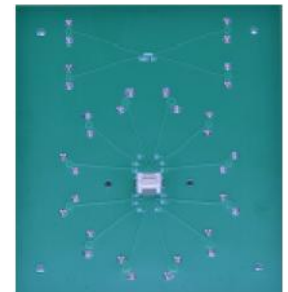
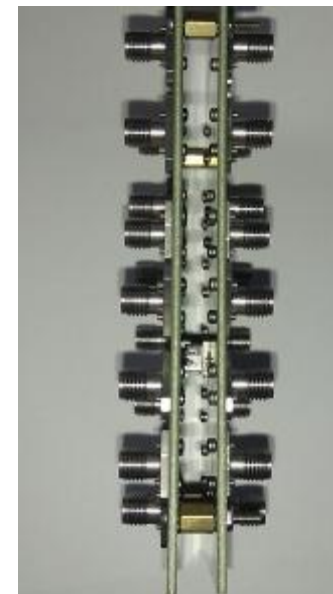
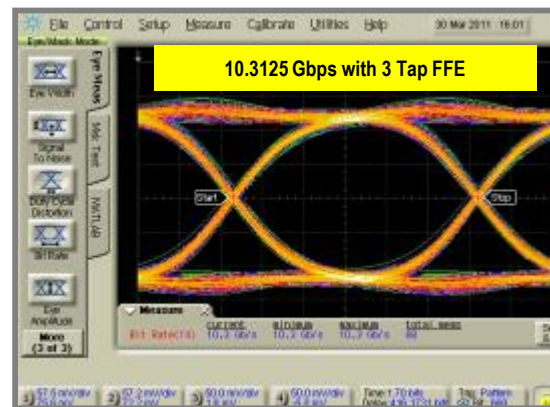
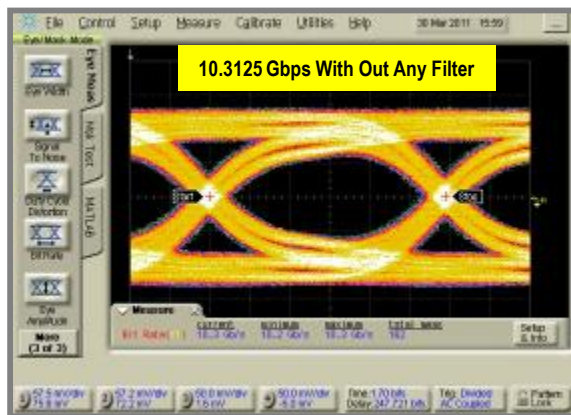
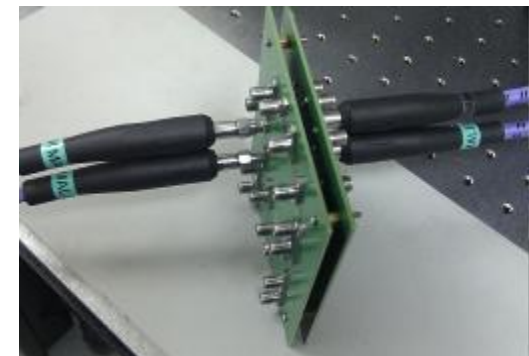

Note: Includes 2.5" of PCB Traces and SMA's



NEXT and FEXT Comparison

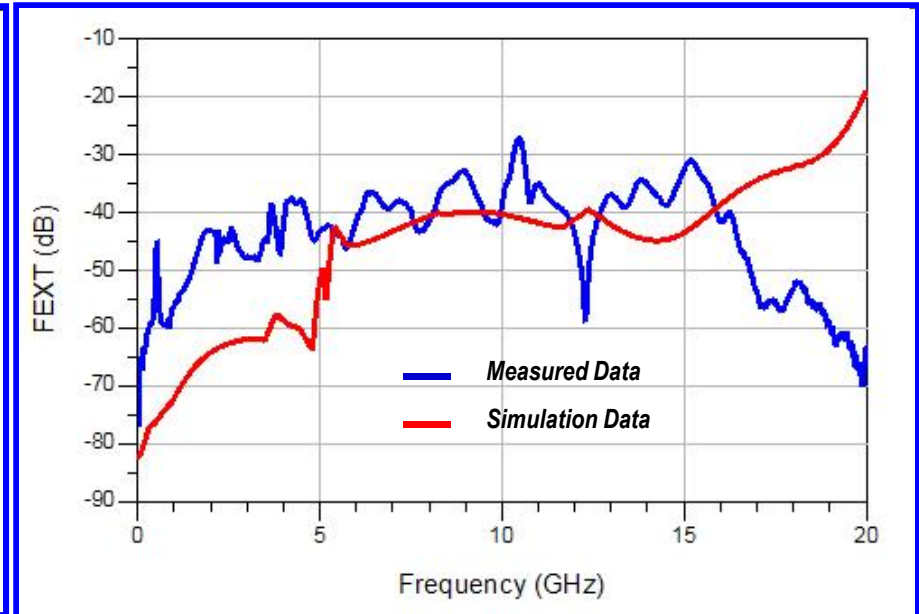
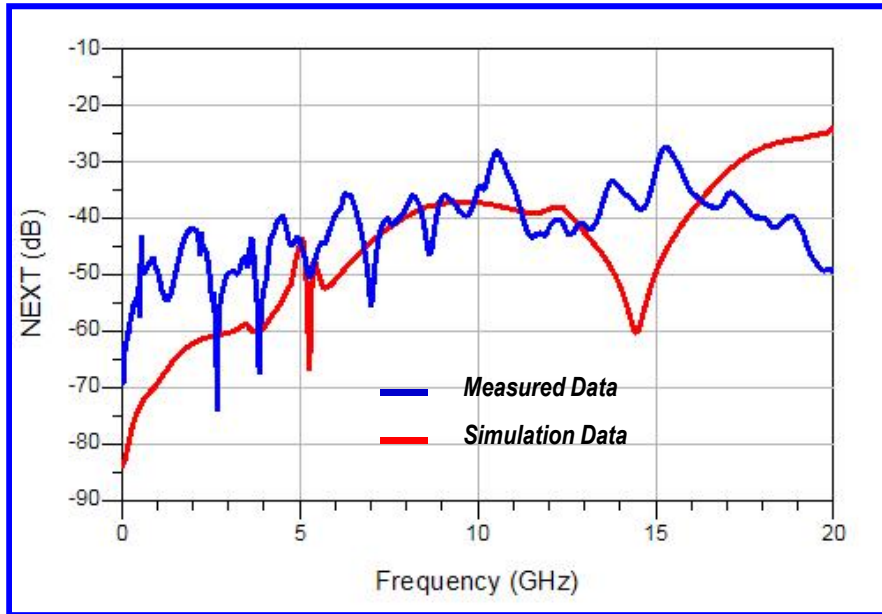

- 35 dB NEXT (S31) over 10 GHz
- 35 dB FEXT(S14) over 10 GHz

Note: Effect of Test Board is Present on the Measurement

Eye Pattern Comparison @ 10Gbps

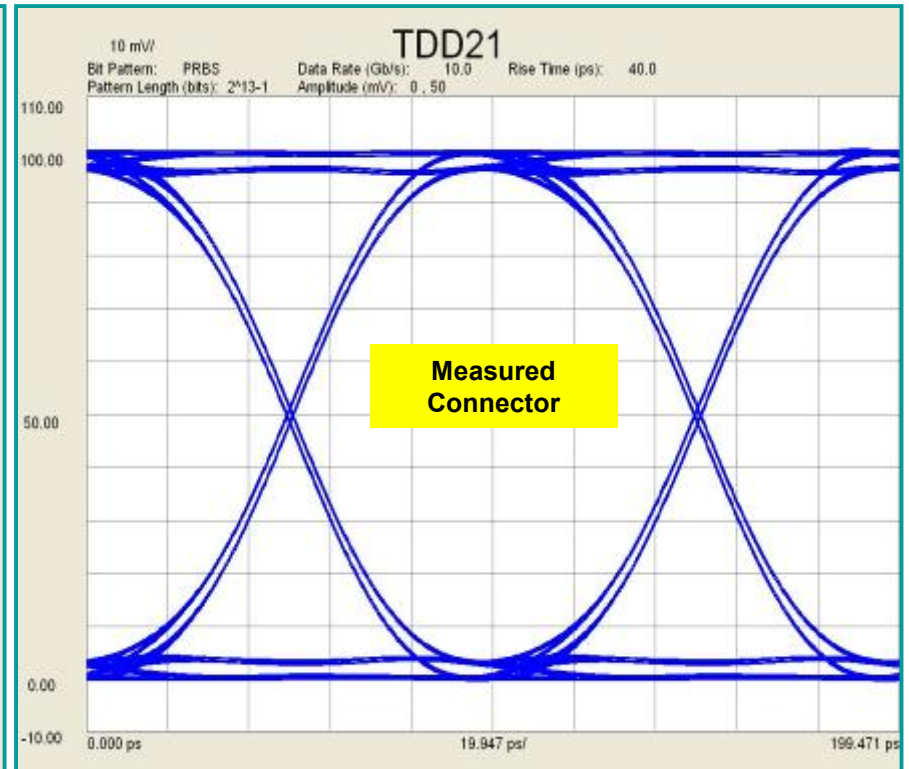
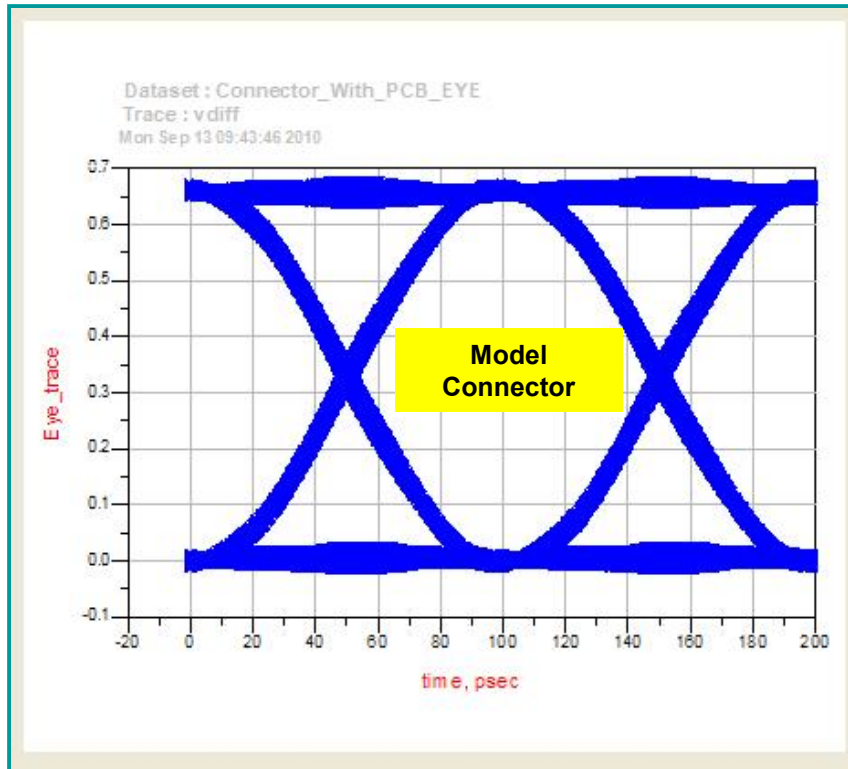



Ultra Low Profile High Speed BTB Connector

- A Hermaphroditic compressive connector that be offered with different heights.
- A fine pitch (0.5mm) low profile connector
- At least 6 Gbps data speeds
- A impedance matched connector with superb x-talk performance.

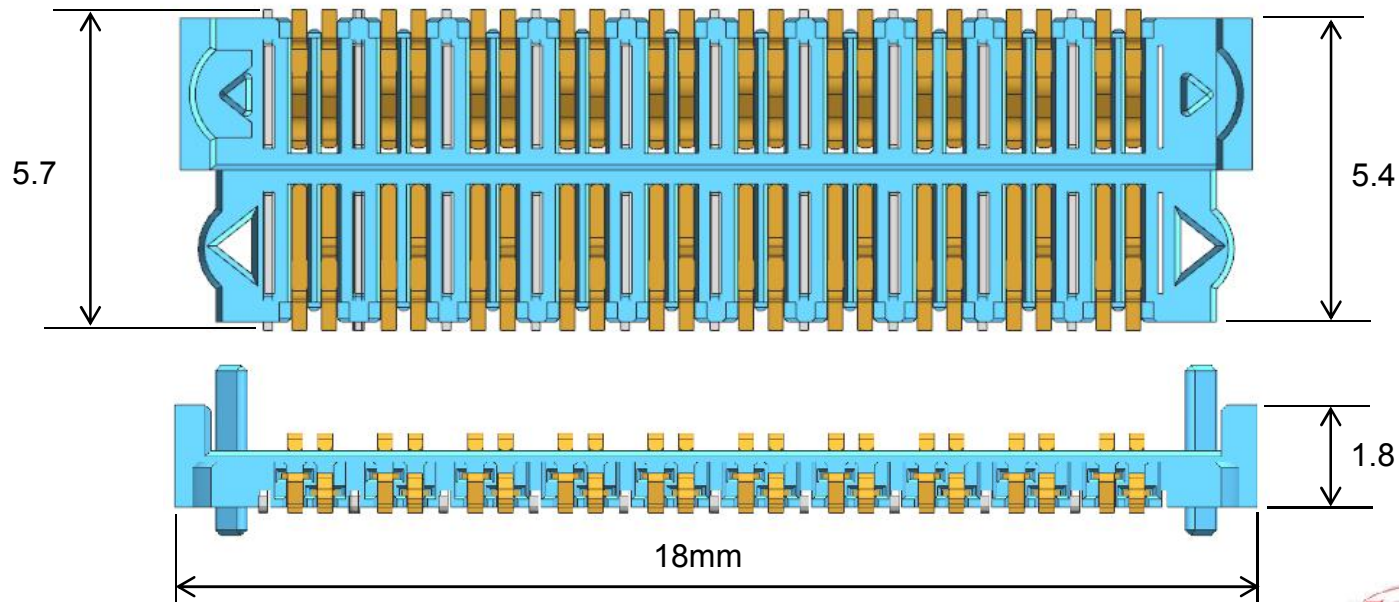
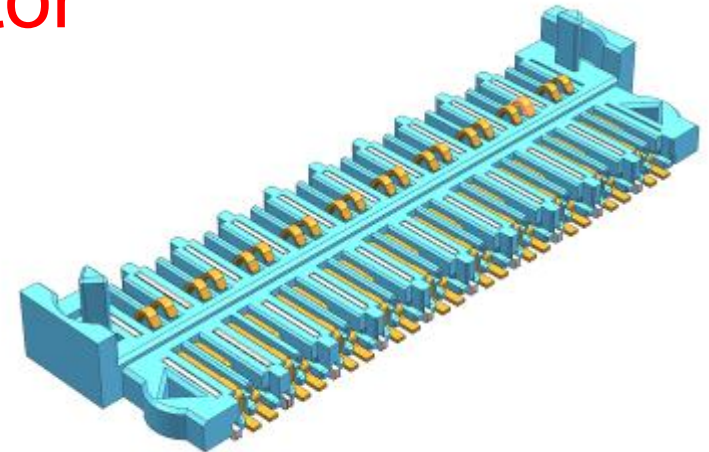

Mating Sequence

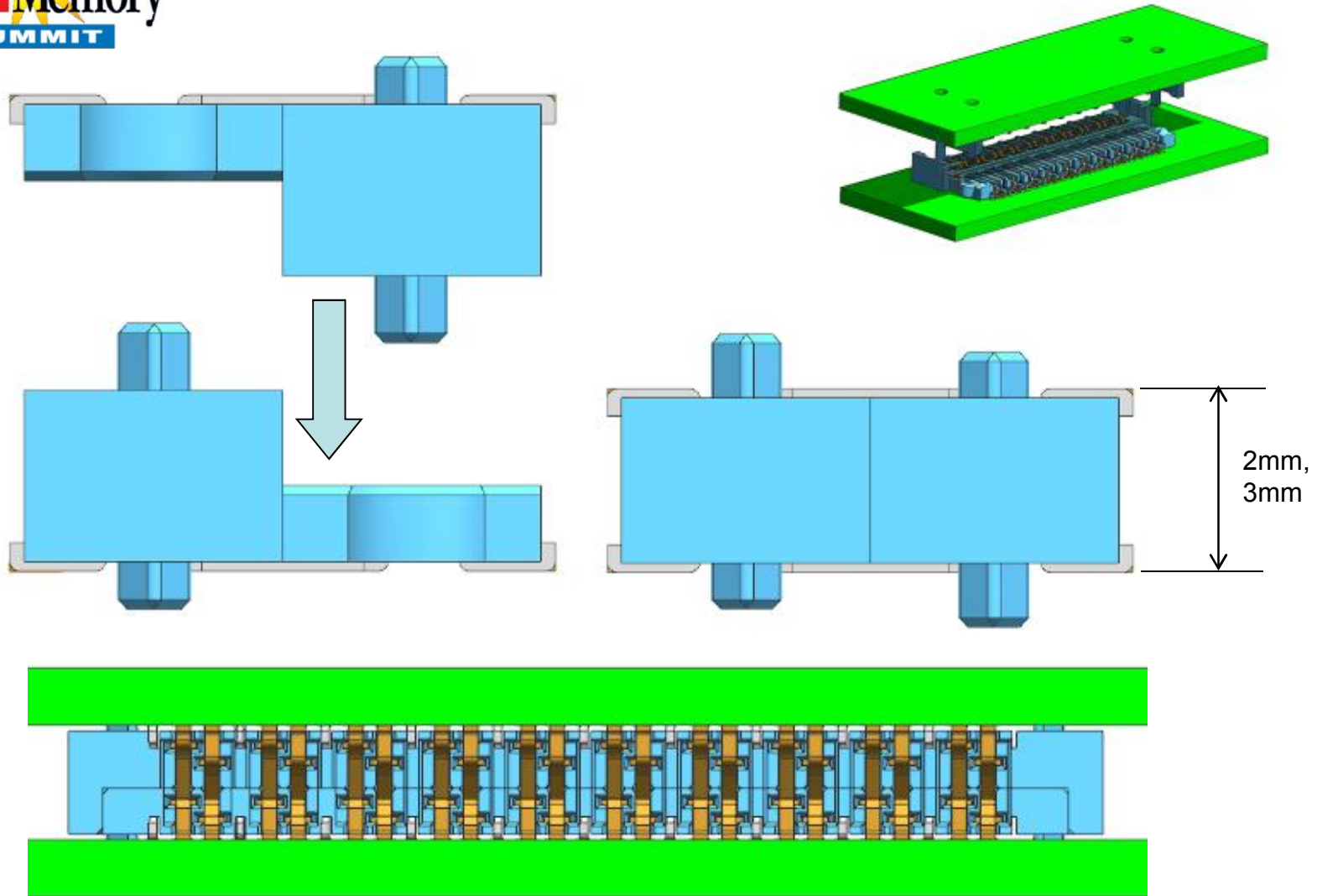



Various Mated Height Available

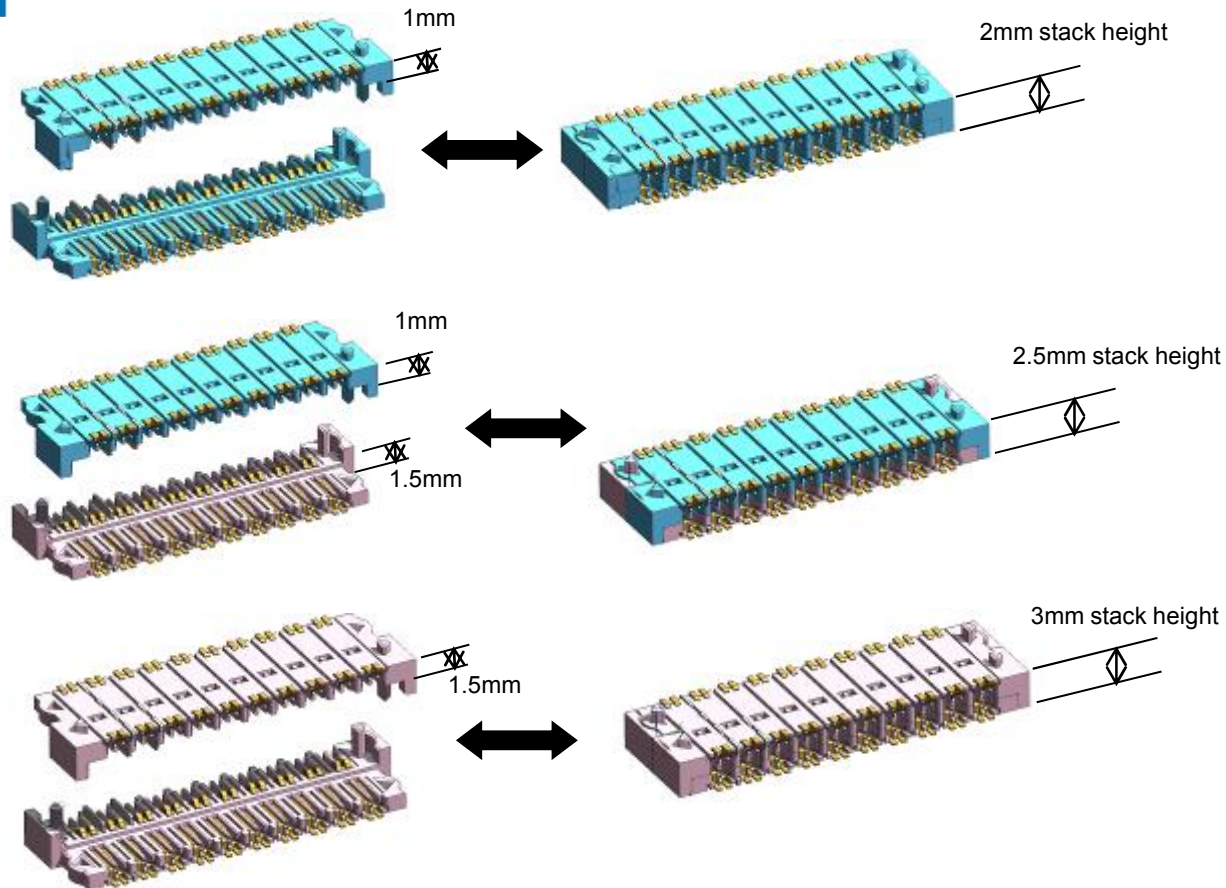

- Different height options with 0.5mm increments.
- E.g.: 1mm & 1.5mm connector heights are offered. Height increments of 0.5mm possible by mating 1mm & 1.5mm connectors
- Higher heights can be manufactured easily without changing 98% of the connector concept.

Simulation Results

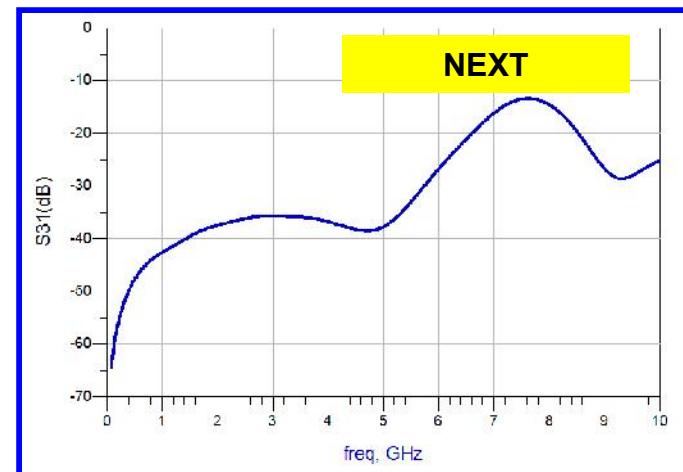
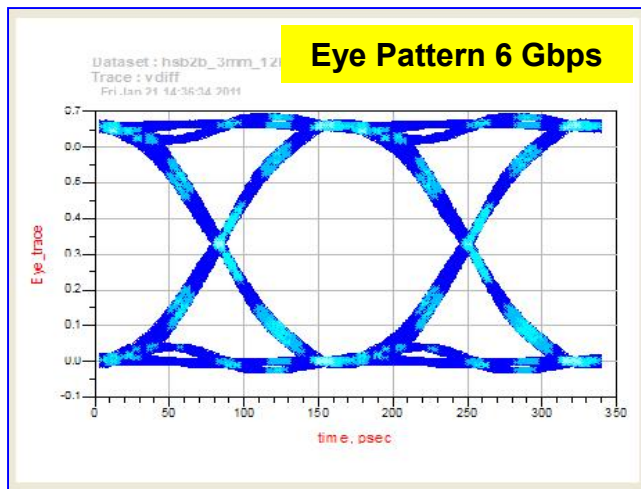
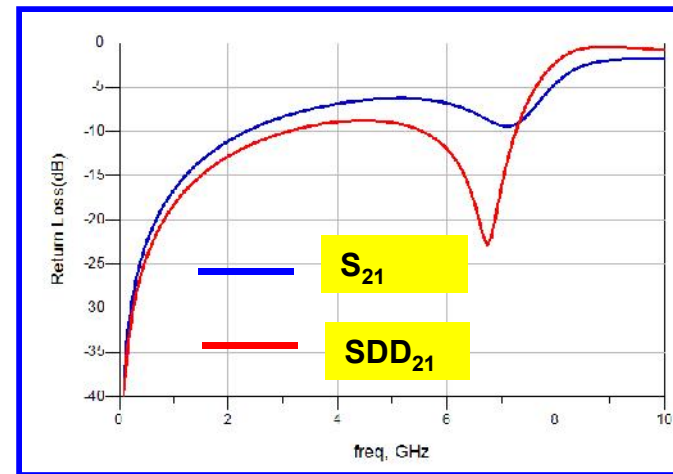
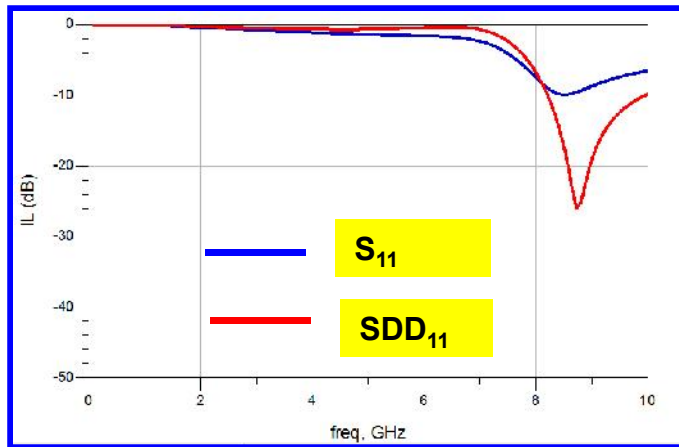

Summary

- Miniaturization of electronic components for SSD Industry.
- Increasing market demand for larger capacity in the fixed form factor.
- Market needs for low profile fine pitch high speed BTB interconnection.
- Stringent SI performance for impedance matching, low cross talk, and low Insertion loss.
- Only Board to Board to Interconnect that caters for Single Ended and Differential Pin Configuration
- 3M High Speed Board to Board Platform provided total solutions for SSD.



SSD Demo Board Available
Showcasing HS-BTB



Biography

Saujit Bandhu has been with 3M for 10 years as Senior Principal Engineer focusing on High Speed connector development. Previously he spent 1 year with Network Technology Research Centre, Singapore, as a Research Engineer working on high speed optical network projects. Previous to his tenure with Network Technology Research Centre, "Saujit" spent 2 years in RPG Netcom Limited, India, working on designing and deploying hybrid fibre coaxial network for CATV and Internet over Cable applications. He holds a B.Sc in Physics and B.Tech in Optics and Opto-Electronics from University of Calcutta, and M.S in Photonics from the Nanyang Technological University, Singapore

Roy Lim has just celebrated his 5th Anniversary with 3M as Principal Engineer focusing on High Speed connector development with an emphasis on Enterprise Network Communication. His training has been on Mechanical Engineering & for recent years, he has been engaged in High speed solutions with deep co-development with SI engineers. Prior to 3M, Roy spent 2.5 years as senior design engineer in JST R&D center in Singapore focusing in Automotive connectors & wire harnessing. Roy started his experience in 'connectors' with AMP-Tyco Singapore as a Molding engineer focusing on connector mold design & tooling qualification for mass production. His Tyco stint lasted 4 years. He holds a B.Eng in Mechanical Engineering from the University of Birmingham, UK.

Qiao Yunlong has more than 6 years of connector design experiences. He was starting as a Plastic Mold Designer in one of the Japan molding company, and then he spent 3 years with Molex on connector design. Currently he is working in 3M APAC as a Principal Product Design Engineer on high speed product development. He holds a B.Sc in Mechanical and Manufacturing Engineer from University of South Australia, and MSc in Engineering Design from University of Loughborough UK.

Alexander W. Barr has spent over 25 years in the interconnect industry having worked at Tyco Electronics and Robinson Nugent before spending the last 9 years at 3M in the Electronic Solutions division. He has a bachelor's degree in Physics from Franklin & Marshall College and a masters degree in Electrical Engineering from Penn. St. University. His particular area of expertise is signal integrity as it applies to high speed connectors and cable assemblies. In addition to holding 9 patents, he has previously authored papers that have appeared in several forums and publications including DesignCon, BiTS and Connector Specifier magazine.





Thank You

For More Information Please Contact:

SAUJIT BANDHU: SBandhu@mmm.com

ROY LIM: RLim@mmm.com

YUN LONG QIAO: YQiao2@mmm.com





Important Notice

3M is a trademark of 3M Company.

Important Notice

All statements, technical information, and recommendations related to 3M's products are based on information believed to be reliable, but the accuracy or completeness is not guaranteed. Before using this product, you must evaluate it and determine if it is suitable for your intended application. You assume all risks and liability associated with such use. Any statements related to the product which are not contained in 3M's current publications, or any contrary statements contained on your purchase order shall have no force or effect unless expressly agreed upon, in writing, by an authorized officer of 3M.

Warranty; Limited Remedy; Limited Liability

3M's product warranty is stated in its Product Literature available upon request. **3M MAKES NO OTHER WARRANTIES INCLUDING, BUT NOT LIMITED TO, ANY IMPLIED WARRANTY OF MERCHANTABILITY OR FITNESS FOR A PARTICULAR PURPOSE.** If this product is defective within the warranty period stated above, your exclusive remedy shall be, at 3M's option, to replace or repair the 3M product or refund the purchase price of the 3M product. **Except where prohibited by law, 3M will not be liable for any loss or damage arising from this 3M product, whether direct, indirect, special, incidental or consequential regardless of the legal theory asserted.**

