



Nonvolatile Design Challenges and Methodologies

Aaron Olbrich, Senior Fellow

SanDisk | Enterprise Storage Solutions

August 11, 2011



Flash is Expensive vs HDDs

HP 600GB 6G SAS 15K rpm LFF (3.5-inch) Dual Port 3yr Warranty Hard Drive

HP Price: \$629.00
MFG# 516828-B21

**\$1.05
per GB**

HP 640GB Multi Level Cell PCIe ioDrive Duo for ProLiant Servers

HP Price: \$14,999.00
MFG# 600-282-B21

**\$23.44
per GB**

New Bottlenecks Exposed → at the System Level

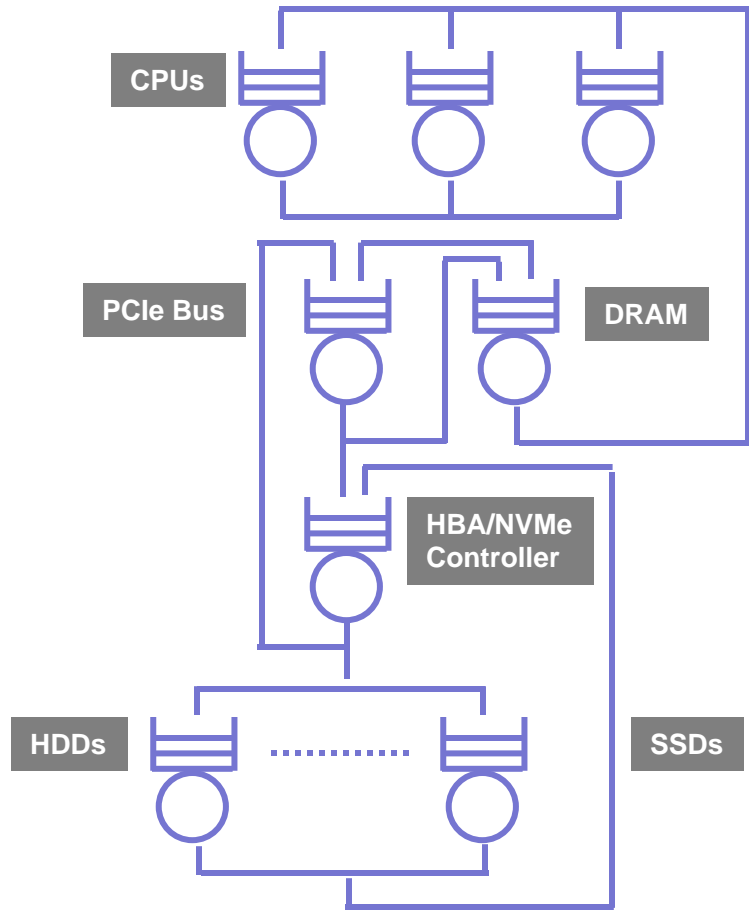

Need to Guarantee QoS with Predictable Max Response Time

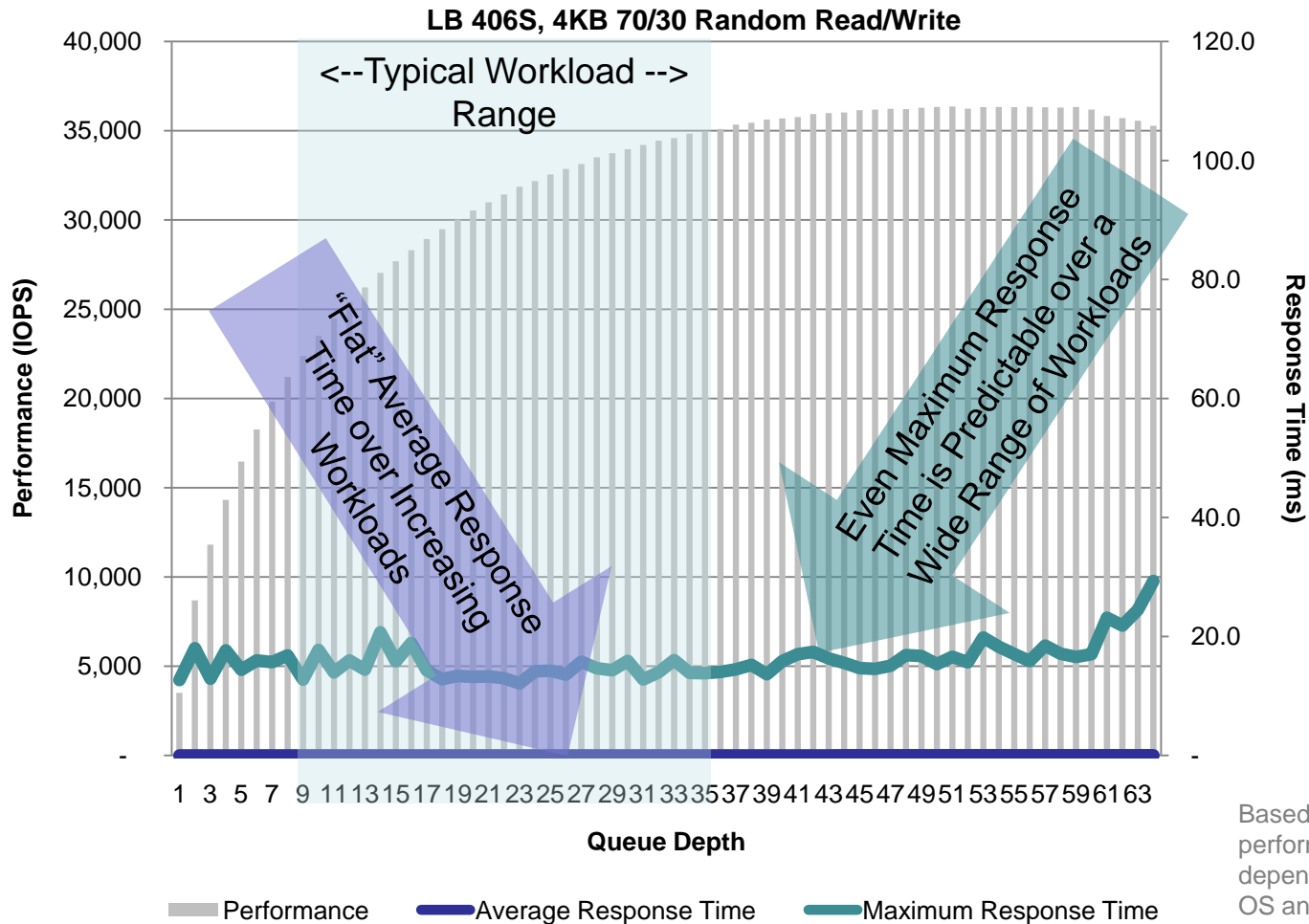

Based on internal testing; performance may be lower depending upon host device, OS and application.

Parallel Architecture Required to Do More Work

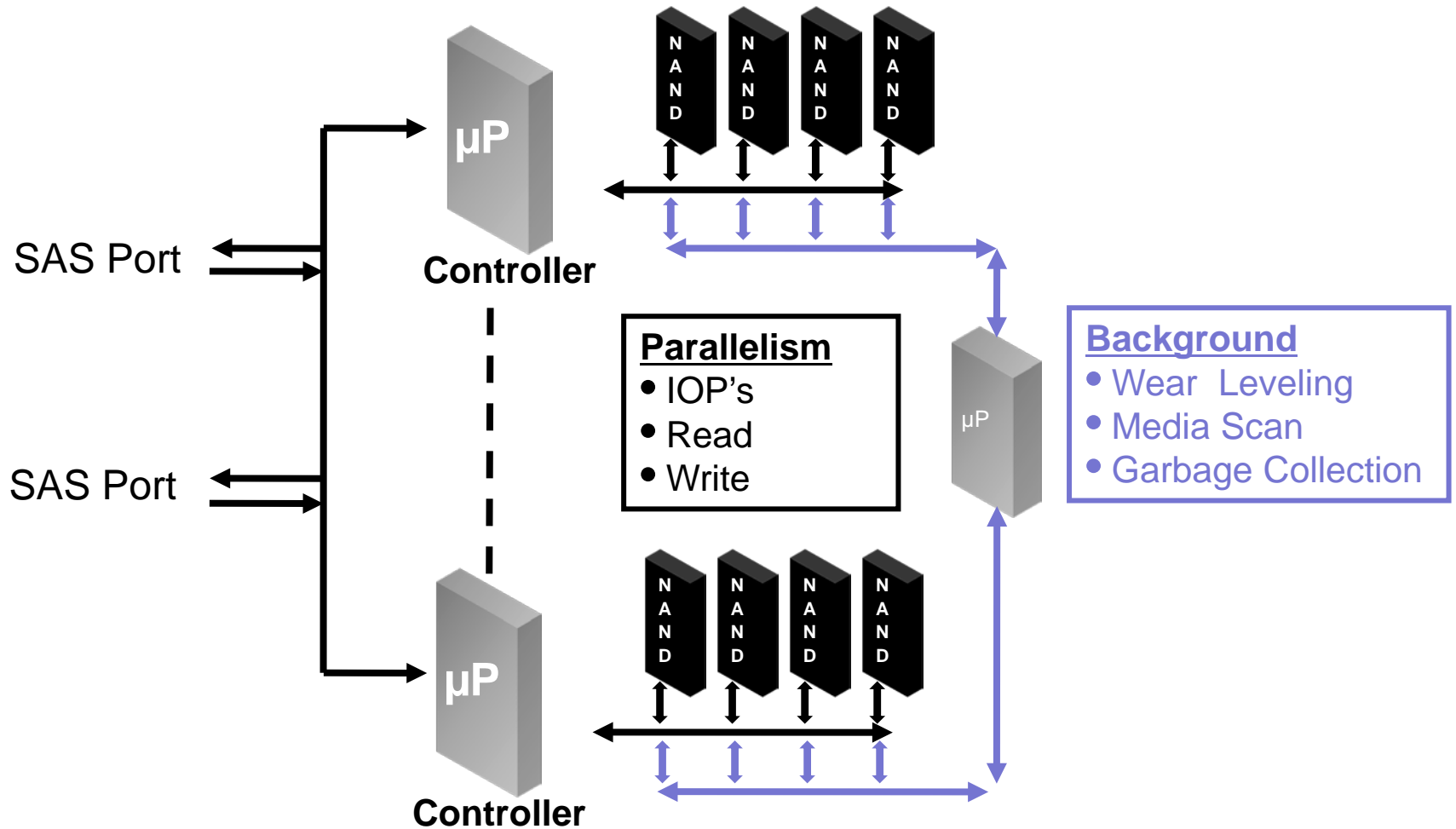

Power Becomes a Critical Issue

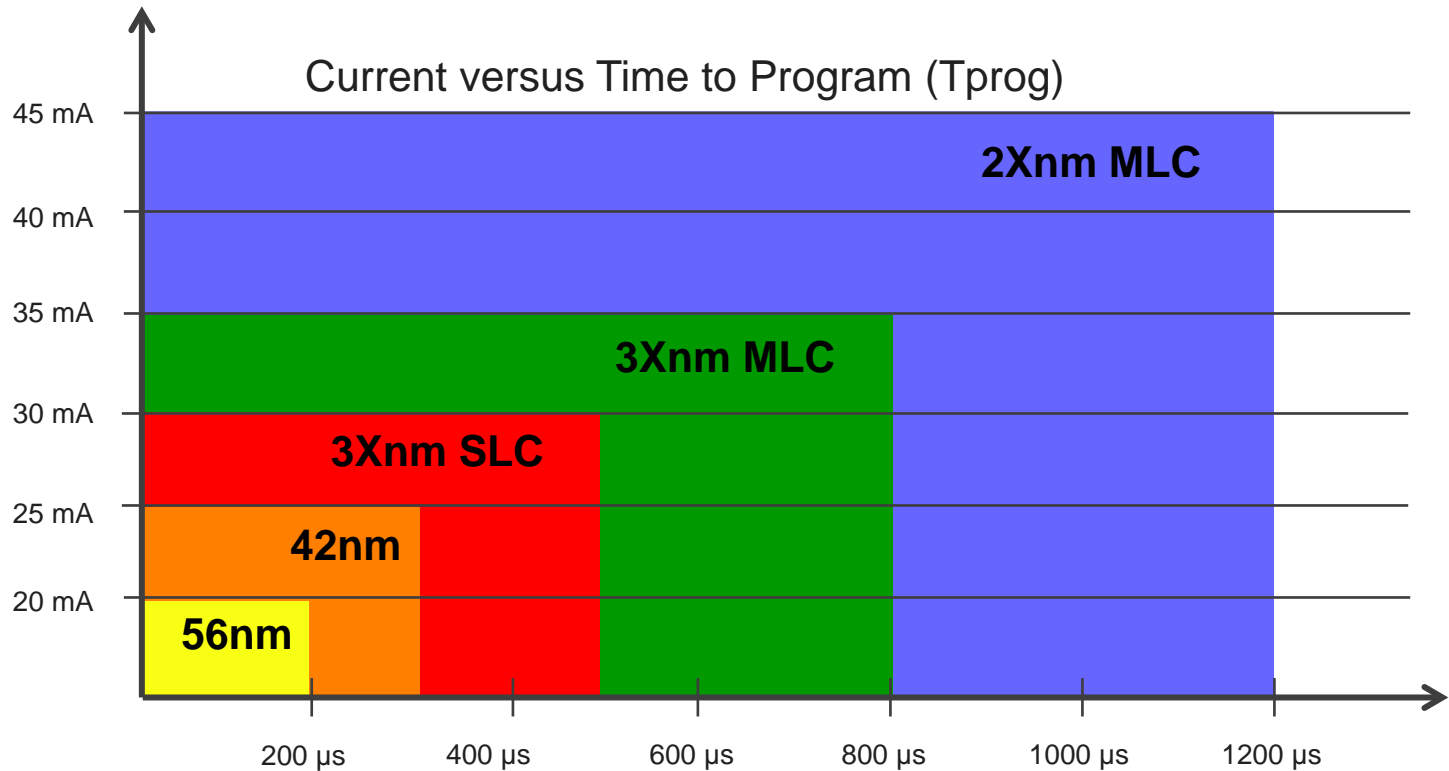

Increasing power of NAND driving up system supply needs



The Challenge → How to DO MORE WITH LESS

Summary – Design Challenges

- More SSDs drives up CPU utilization
- Parallelism enables more work (and drives up power needs)
- Power budgets are significant design factor
- Maintaining quality of service (QoS) essential during peak workloads



ANY QUESTIONS?

Thank you!

Aaron Olbrich, Senior Fellow

SanDisk | Enterprise Storage Solutions

www.sandisk.com/enterprise-storage-solutions