

NVME-based MidPlane FTL

Bharadwaj Pudipeddi
CTO, BiTMICRO

Abstract: Cloud-Scale PCIe SSDs

- NVMe and SFF-8639 create new challenges: *Thermal, Cost, Scale*
- Problems of localized FTL (in the SSDs) and fully centralized FTL (in the Xeons)
- The solution: a de-localized shared FTL built for cloud-scale rack-optimized systems

Server-Class PCIe SSDs: Cost Trendline

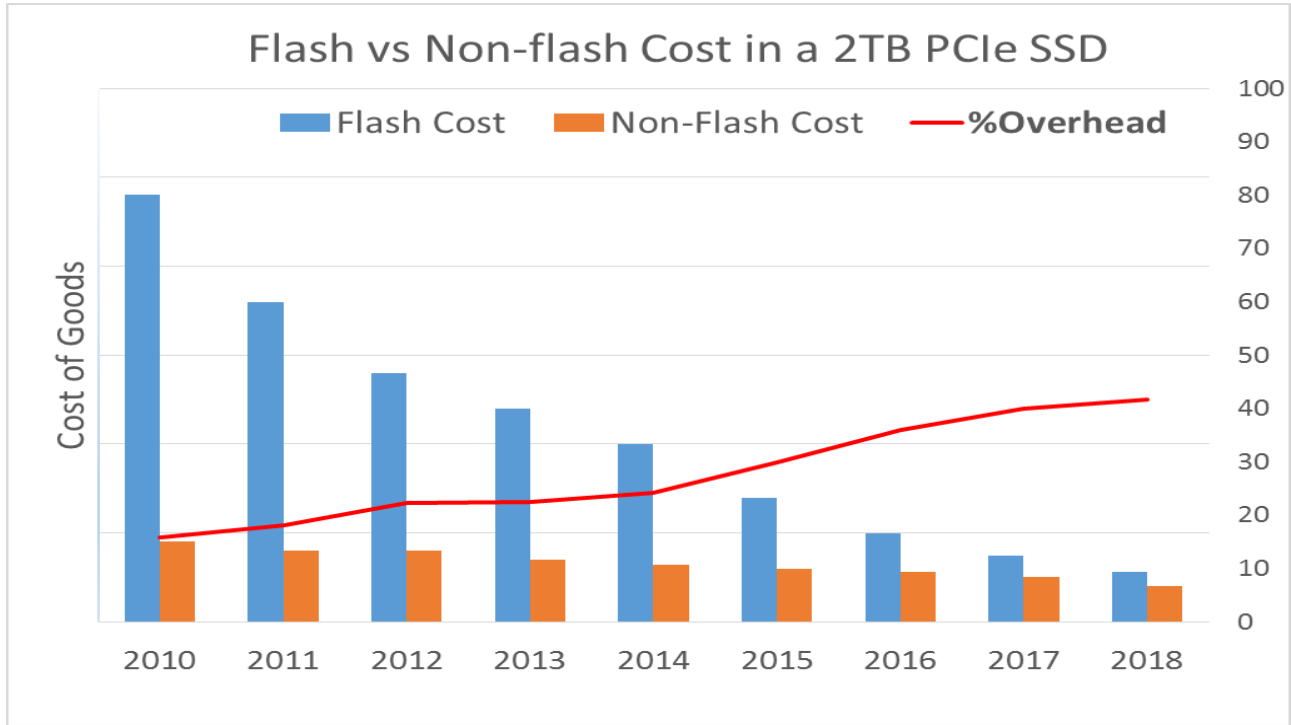

Common Solutions to Flash Cost Efficiency

- Run FTL in Xeon (even integrate into filesystem)
- Increase density of SSDs (amortize overhead \$\$)

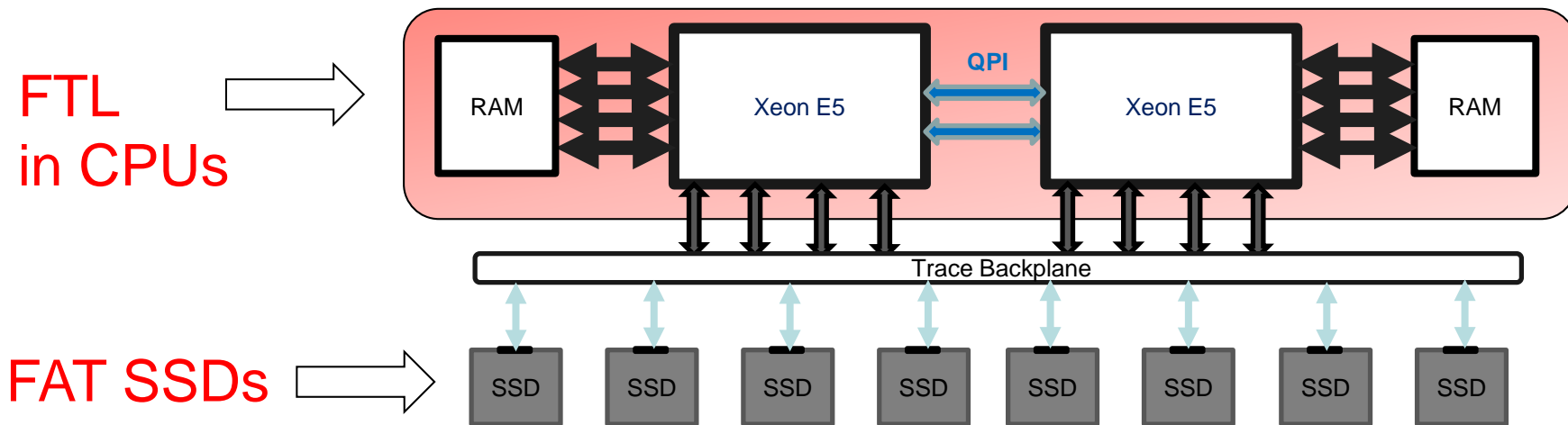

Problems of Current Approaches

- FTL running on CPUs –
 - Unpredictable: varies with Xeon workload
 - Does NOT benefit from custom h/w accelerations
 - ECC does not scale
- FAT SSDs (4TB, 8TB, 16TB etc.)
 - Harder to design with limited board space
 - Too localized: limited FTL efficiency, costly scale-out
 - Huge failure disruption: losing 8TB is worse than 2TB
 - Wasted PCIe Energy: Performance bottleneck in CPU's I/O path

First: Anatomy of a Server PCIe SSD

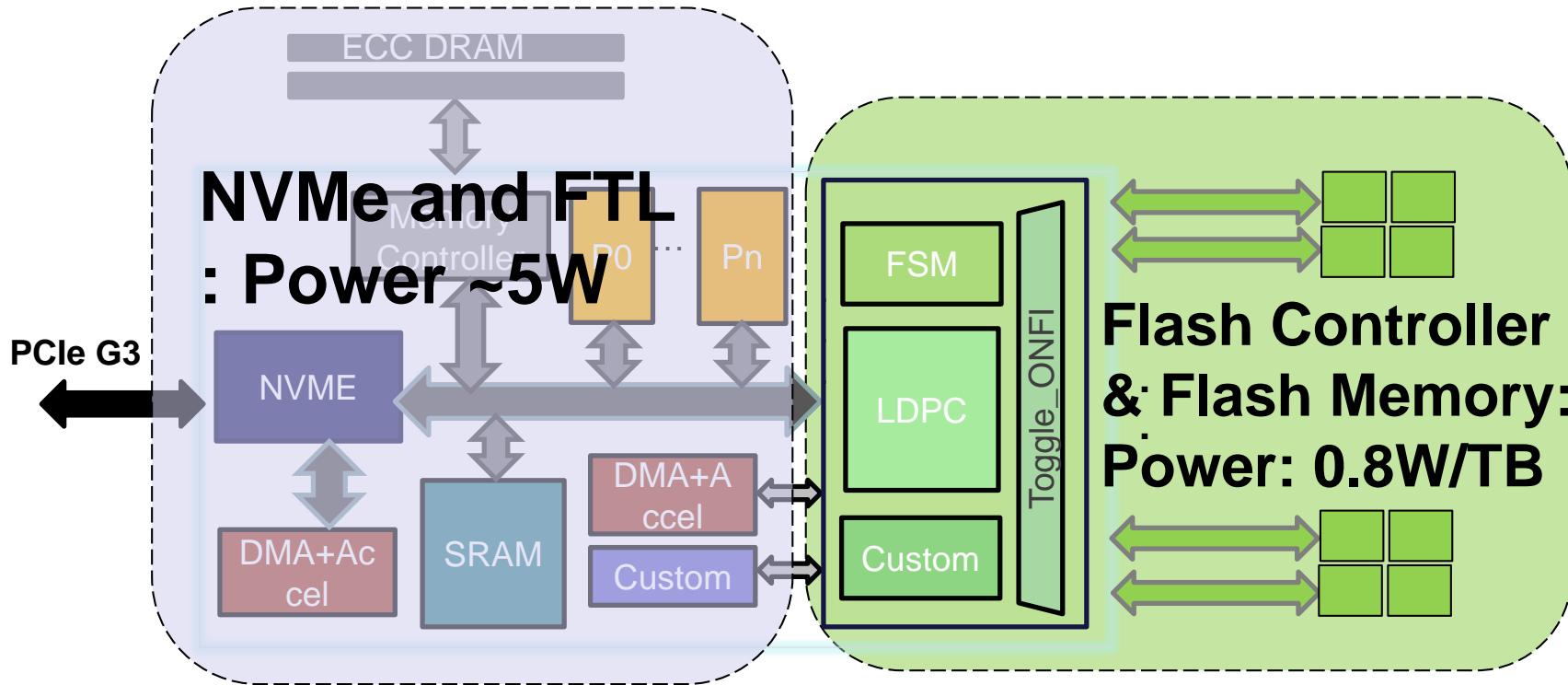

The Midplane Solution:

- De-localizing FTL: Separate NVMe+FTL Card
 - Larger Pool of Flash: Higher Data Efficiency
 - Consistent FTL performance
 - Scope for Custom H/W features
- Separate Flash Memory Modules: Low-power
 - Scaling Error Correction with Capacity
 - Higher Capacity with more Board Space

NVMe-based Midplane FTL

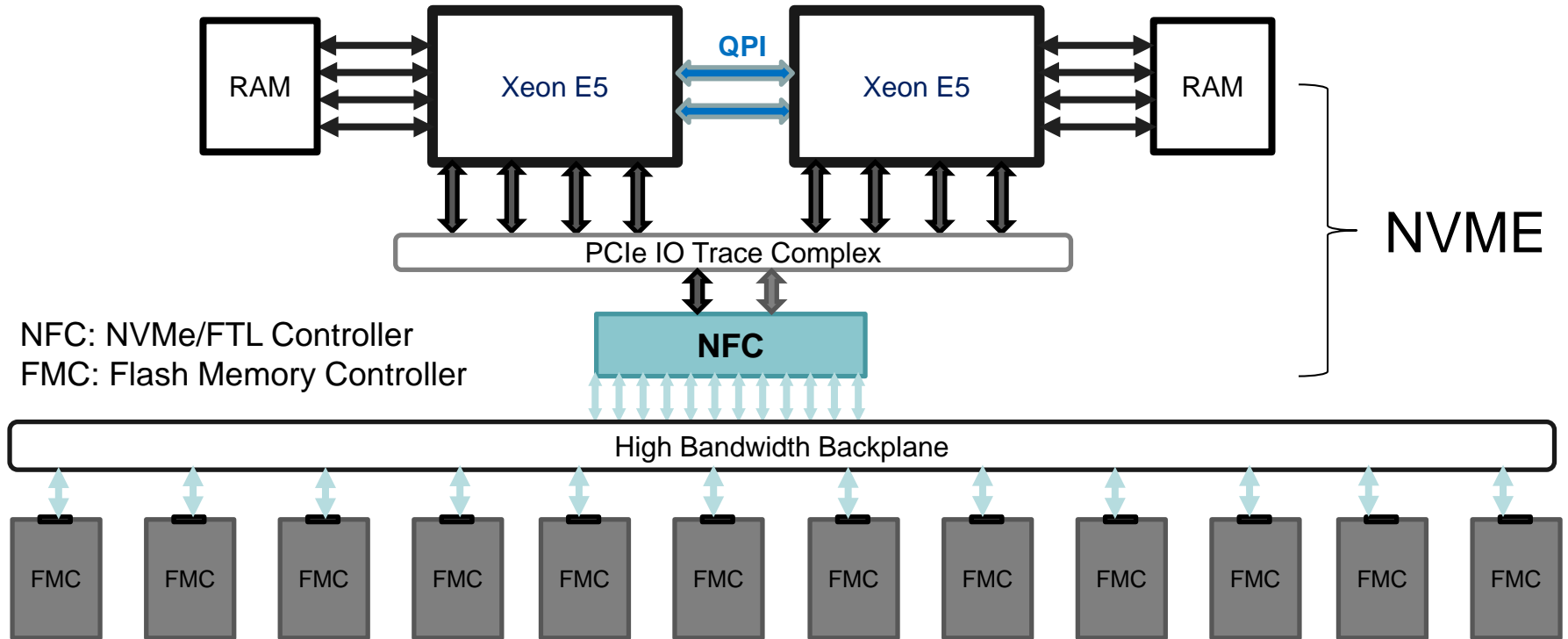

Advantages of Midplane-FTL Server

- Overall: Much better power efficiency
- Thermal problem localized to NVMe FTL Controller (NFC)
- Easier Hot Plug / Add Solutions for FMCs
- Higher Density

Expect to use 50% less power, 30% more density, and much lower costs



*Flash8x2TB =
1 NFC + 8 FMC*

*Flash6x2TB =
1 NFC + 6 FMC*

Topology: 1-level

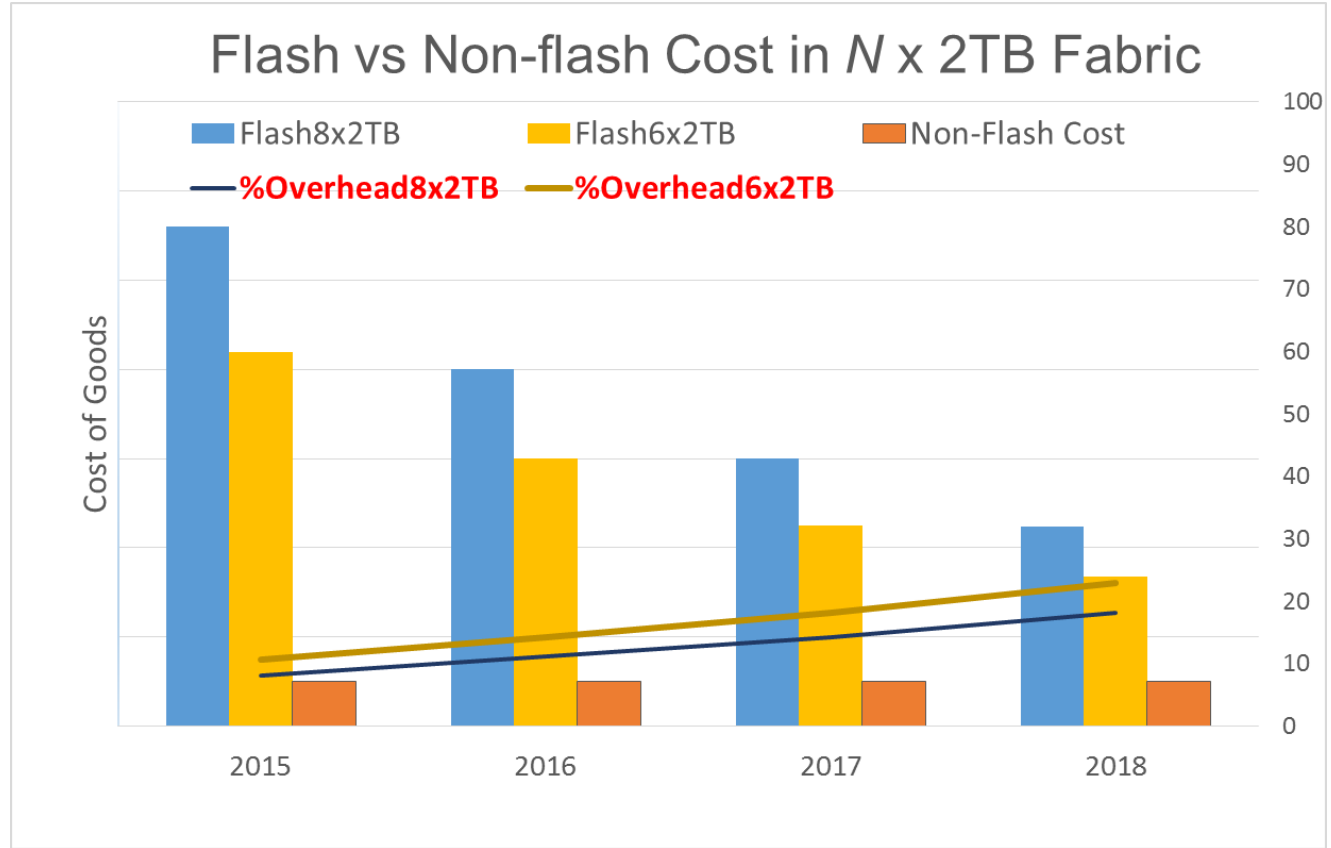

Power Savings: 80% (Flash8x2TB); 50%(Flash6x2TB)

Challenges for Midplane Solution

- NVMe FTL Controller (NFC) – ability to parallelize and efficiently run FTL across larger pools
- High B/W Backplane “cable-friendly” Interface
- NFC Failure FRS (Dual-NFC mode)
- NFC Metadata Power-loss Protection

Using smart hardware customization, and spanning FTL algorithms – these challenges can be met!



Questions?

About the Author

Bharadwaj Pudipeddi (short form: Bharad)

- CTO and VP of Engg, BiTMICRO Networks, Fremont, USA
- BiTMICRO which makes military-grade SSDs has recently announced SSD and All Flash Arrays for Cloud/Enterprise
- Previously worked as Architect at Violin Memory, 3Leaf Systems, and Intel Corp on key products including AFAs and Xeon processors
- Please contact me at bharadwaj@bitmicro.com
- Visit us at the BiTMICRO stall in the FMS exhibit hall