



FMS2015 - Session 101C

UFS is Ready

To Power New Generation of Mobile Devices

Ben Wu

Technical Marketing Manager

SK hynix America

The best medicine for brain health

Is

Yawning



Self-Portrait, Yawning
by Joseph Ducreux, c. 1783.

Source:
<https://en.wikipedia.org>
<http://www.naturalnews.com/>

Outline

- **Mobile Storage Trend and UFS Development**
- **SK hynix UFS Product Announcement**
- **UFS Adoption on New Generation Mobile Product**

UFS: The New Generation Mobile Storage Interface

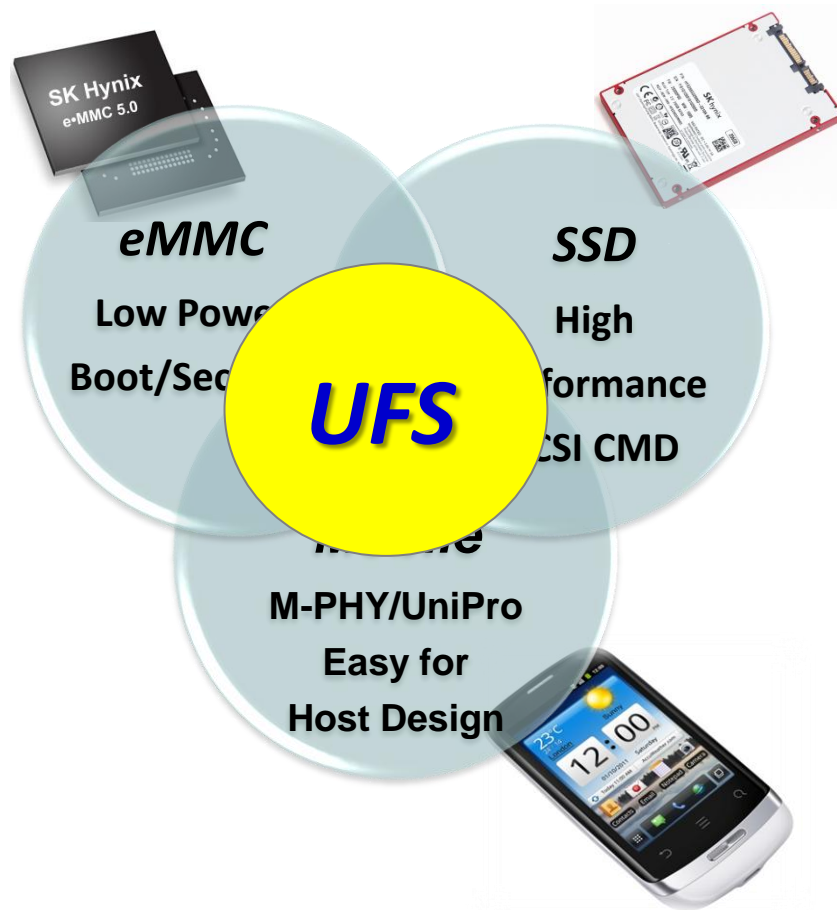

High Bandwidth and IOPS

Bigger Storage Capacity

Better Power Efficiency

Stronger Computing Supportability

UFS Development Roadmap

- JEDEC UFS1.0 in 2011
- First Smartphone with UFS in 2015
- Multiple UFS device, SoC, OS support in 2016
- UFS combined package, external UFS, automotive UFS in near future



Flash Storage Solution Interface Trend

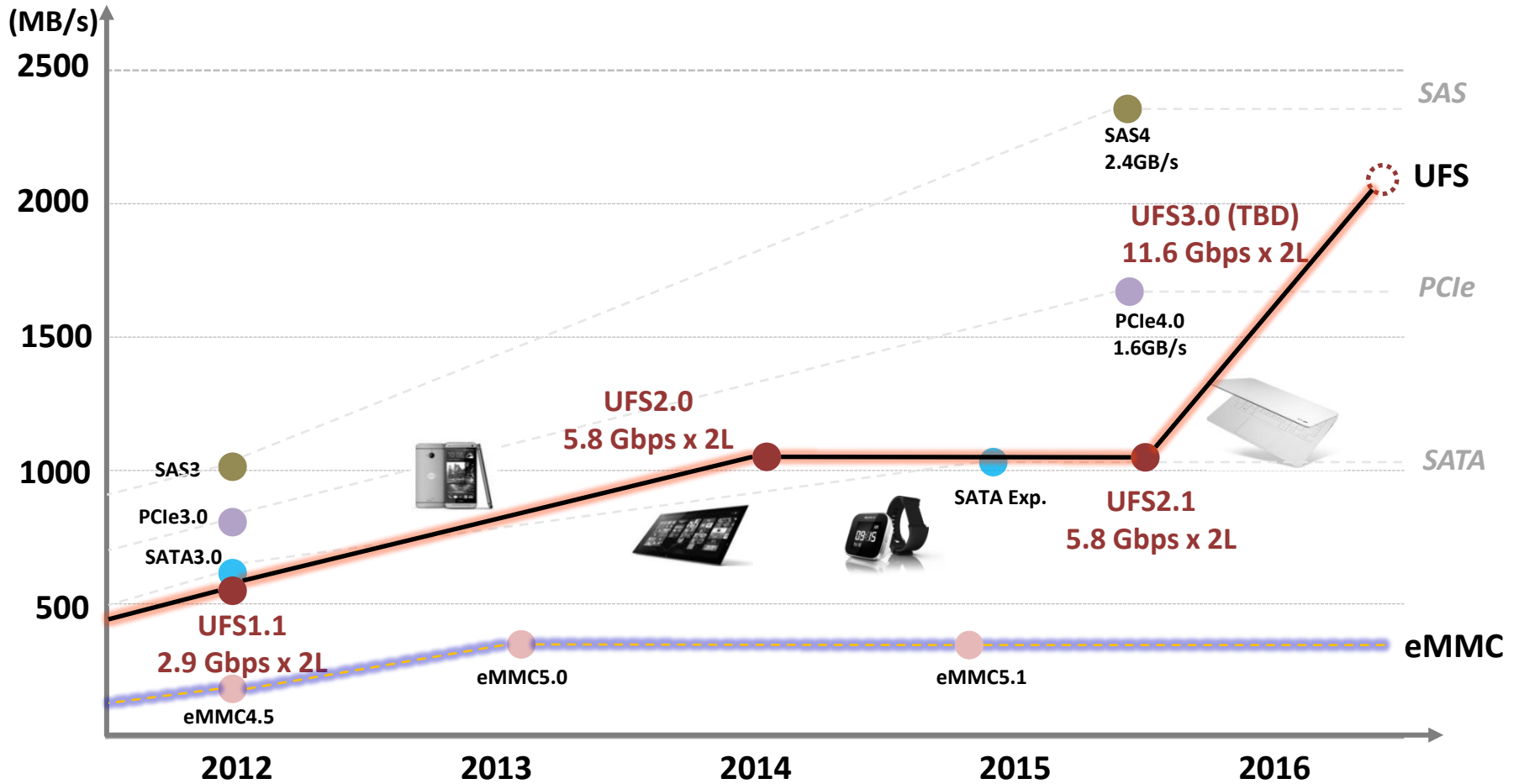

SK hynix UFS 2.0 Announced In July 2015

UFS 2.0 (Gear3, 2 Lane)

Remarkable Performance

User Experience Improvement

- 16GB
- 32GB
- 64GB
- 128GB
- Seq. Read 780MB/s
- Seq. Write 160MB/s
- Ran. Read 32K IOPS
- Ran. Write 17K IOPS
- 3X Read
- 1.5X Write

**Please visit
Booth #107**

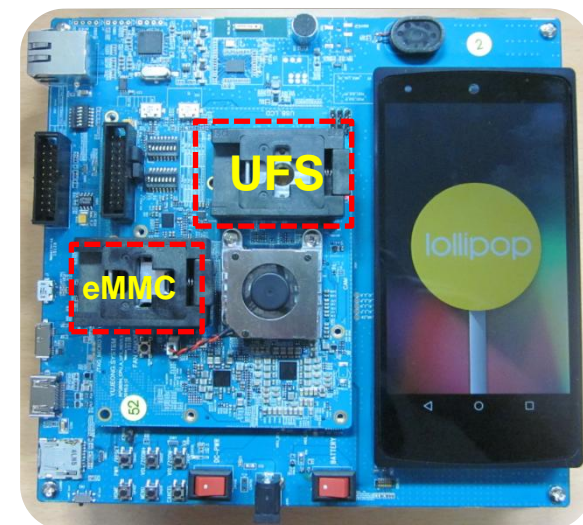

SK hynix UFS2.0 Industry Leading Performance

■ Read Priority Policy (example)

- 32GB UFS2.0, 8GB preload
- Read/Write Mix workload

■ Performance Advantage

- Minimize R.R degrading while background write
- Sustain stable performance even less than 2GB free
- 99% latency within 3ms (QoS)

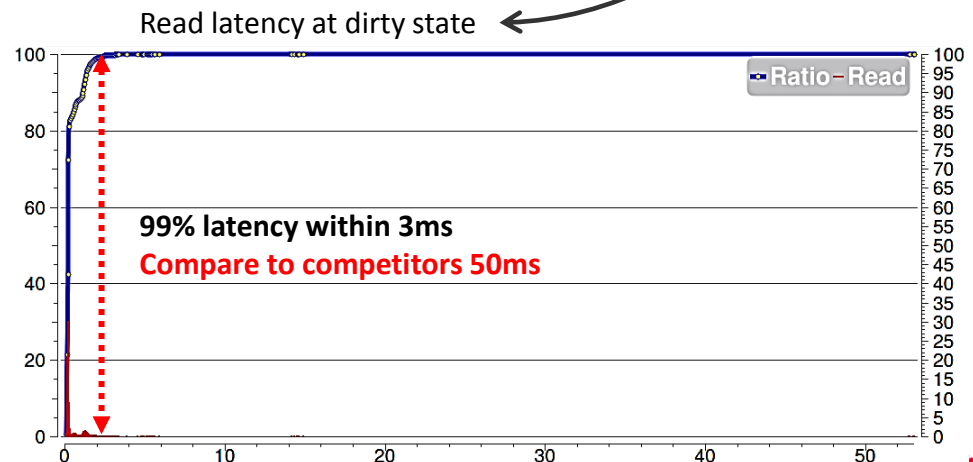
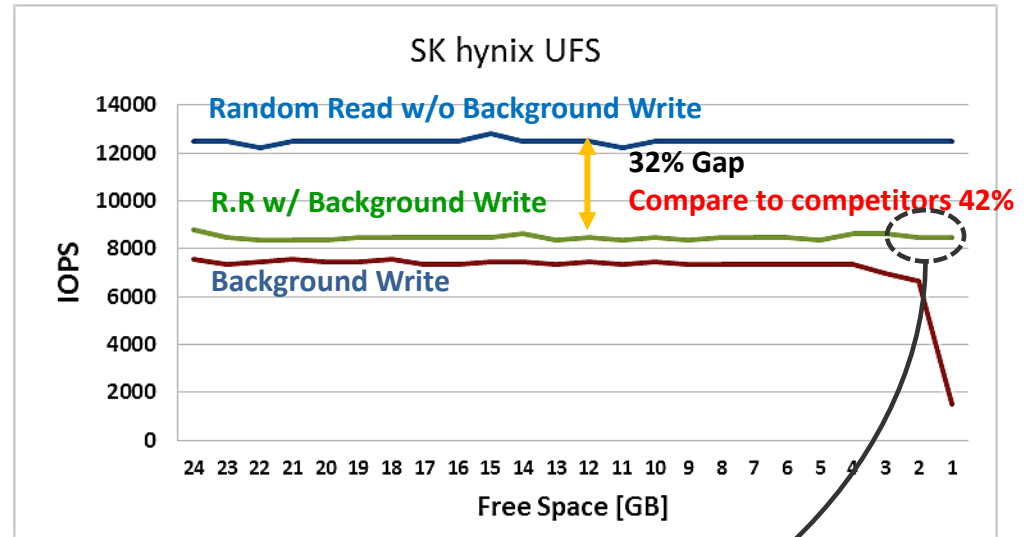

UFS Command Queuing Feature

Benchmark Testing (Multi-tasking)

Apps	R/W	CNT/sec
Hangout	W	23.7
Movie Play	W	1.0
	R	3.6
Web Surfing	W	5.3
	R	7.4
YouTube	W	1.4
	R	0.2
Facebook	W	9.3
	R	0.7

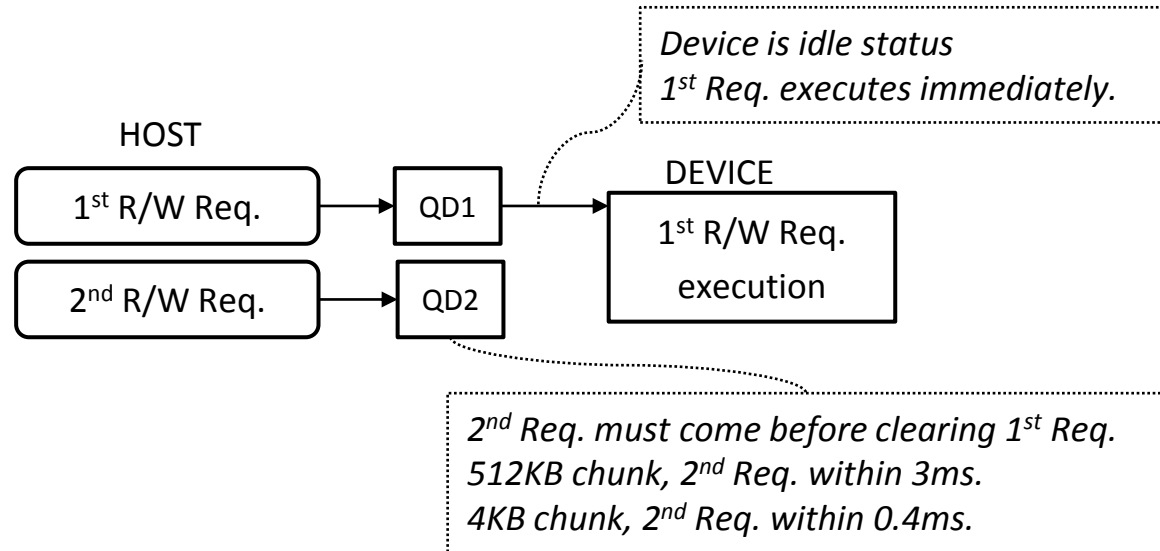

- UFS Design for multi-tasking
- Current applications do not take advantage of multiple queue feature
- Unleash application programming on storage IO request



High End Mobile Storage Market Technology Adoption

Interface Migration Trend

- Premium Smartphone adopt both UFS & eMMC5.1

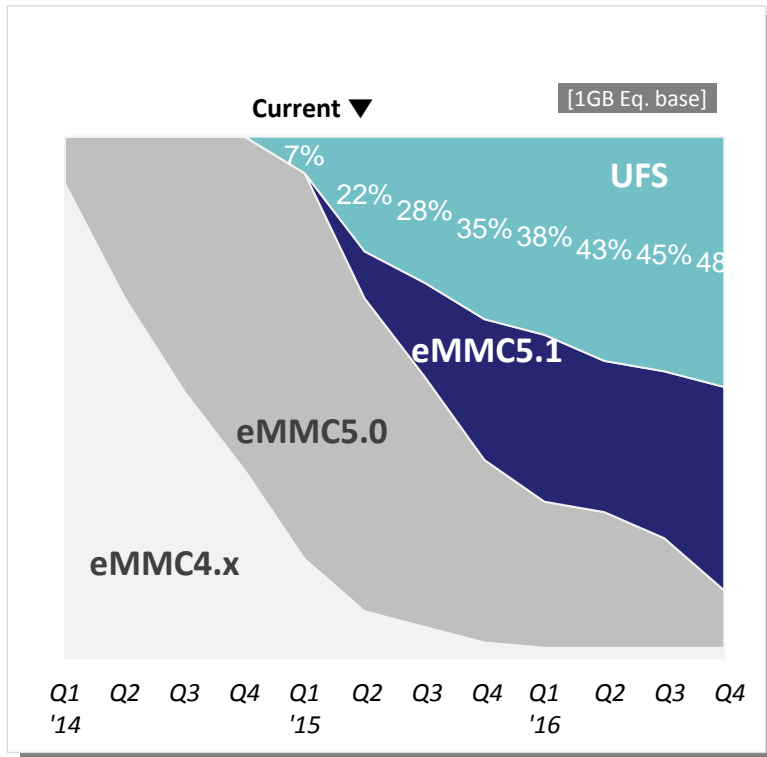

UFS Demand Forecast

- 32/64GB major density

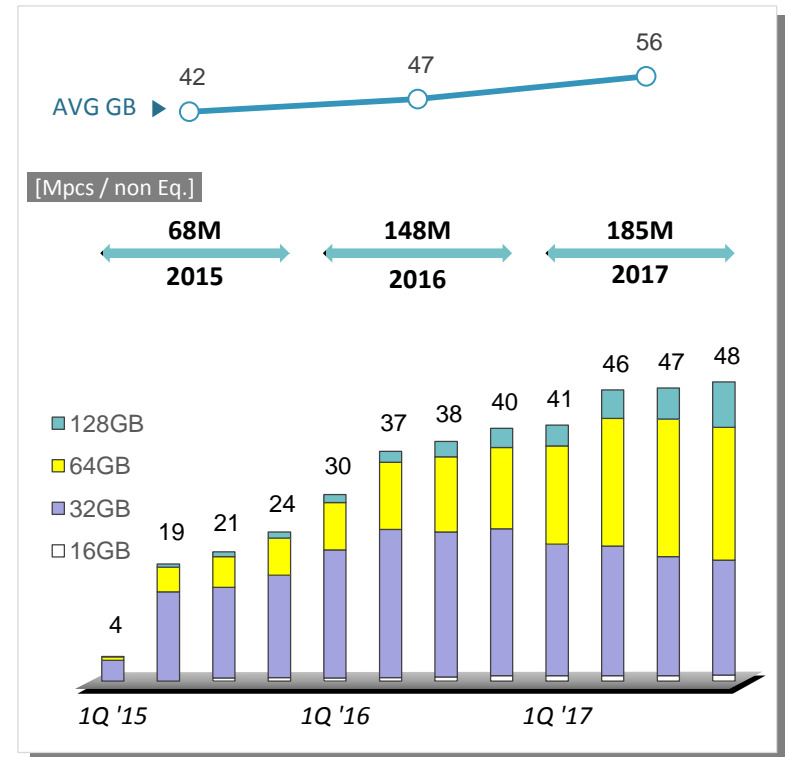

(Source: SK hynix Marketing)

Summary

- SK hynix industry leading UFS2.0 now sampling
- Premium smartphone UFS adoption >30% by end 2015
- Industry collaboration needed to unleash full potential of UFS

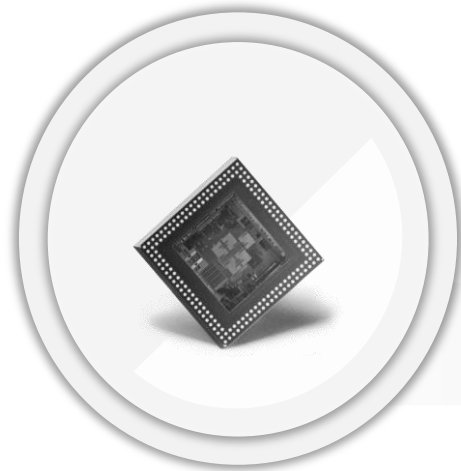

Mobile AP



New UFS



Mobile Application



Win !!

